

Crease the diagonals

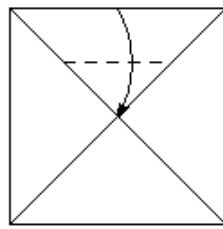

Fold the top edge to the center point, creasing only between the diagonals

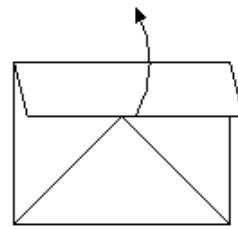

Unfold

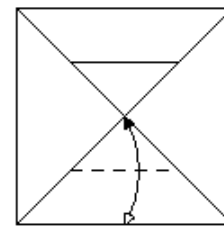

Repeat on the bottom (fold and unfold)

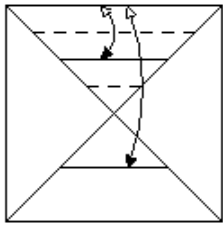

Fold and unfold on 1/4 and 3/4 marks

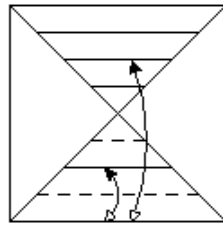

Repeat on the bottom

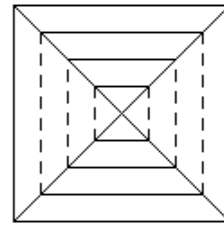

Repeat on left and right sides

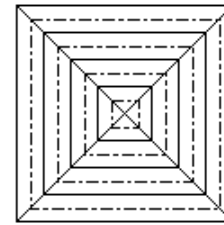

Turn over, and crease in between the squares in the opposite direction

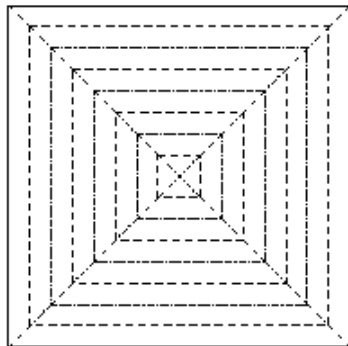

Final crease pattern

- Valley fold
- Mountain fold

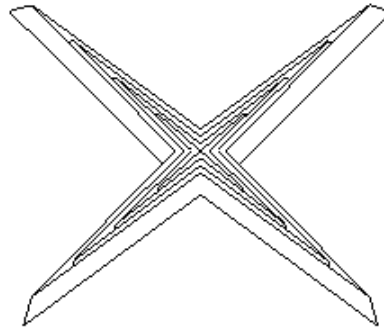

Folding the crease pattern completely forms an "X" shape

Partially opening it forms a hyper

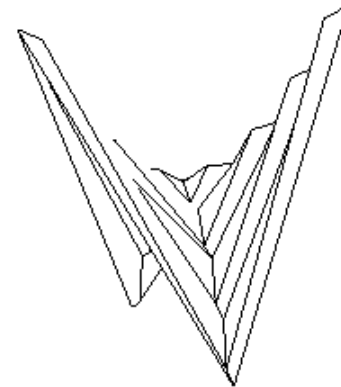

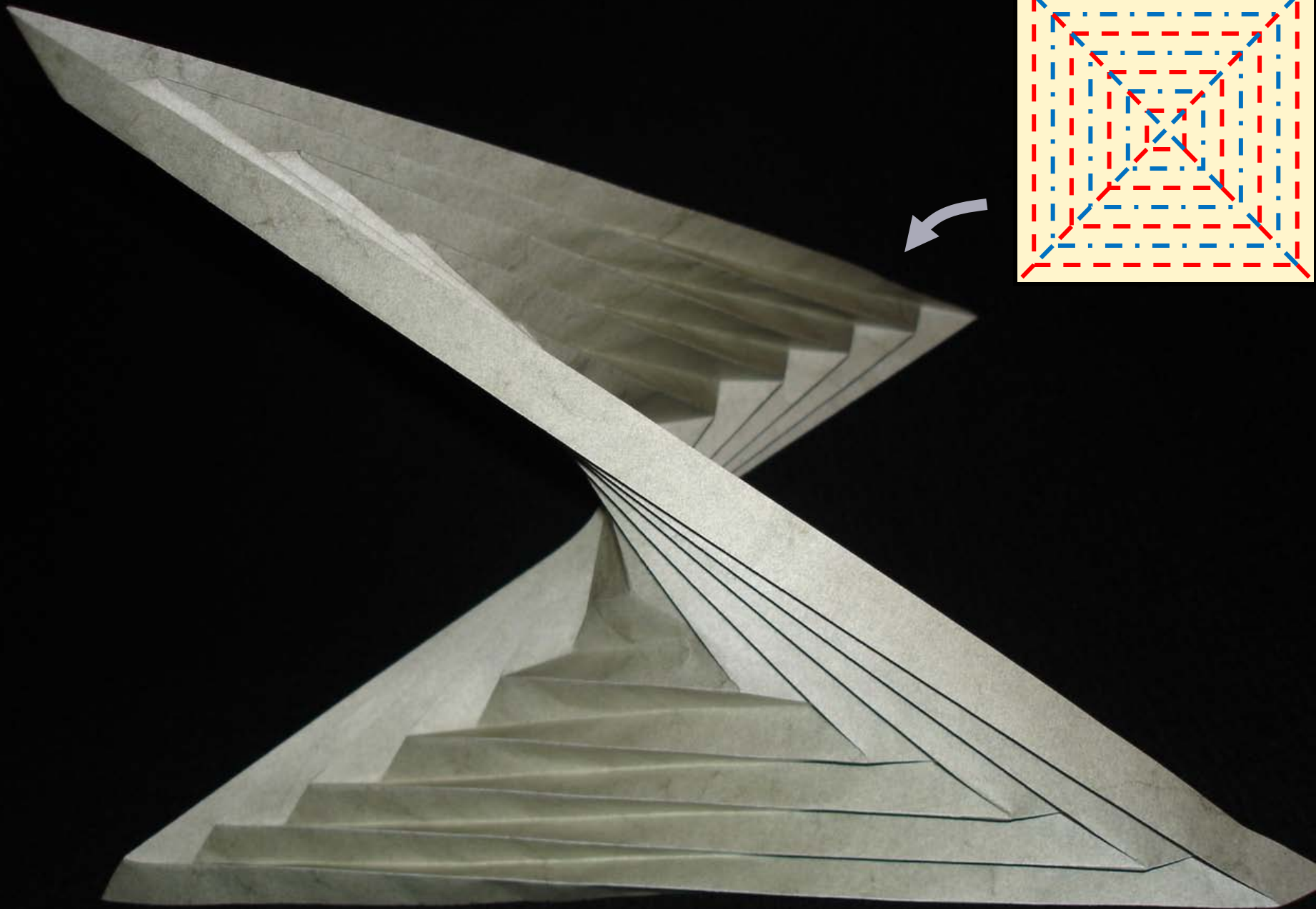

[Albers at Bauhaus, 1927-1928]

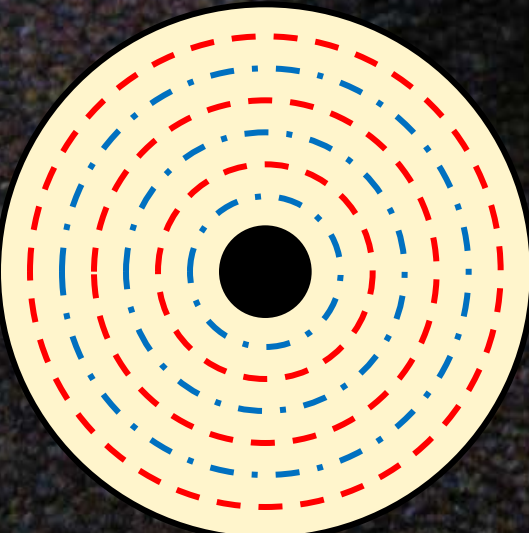
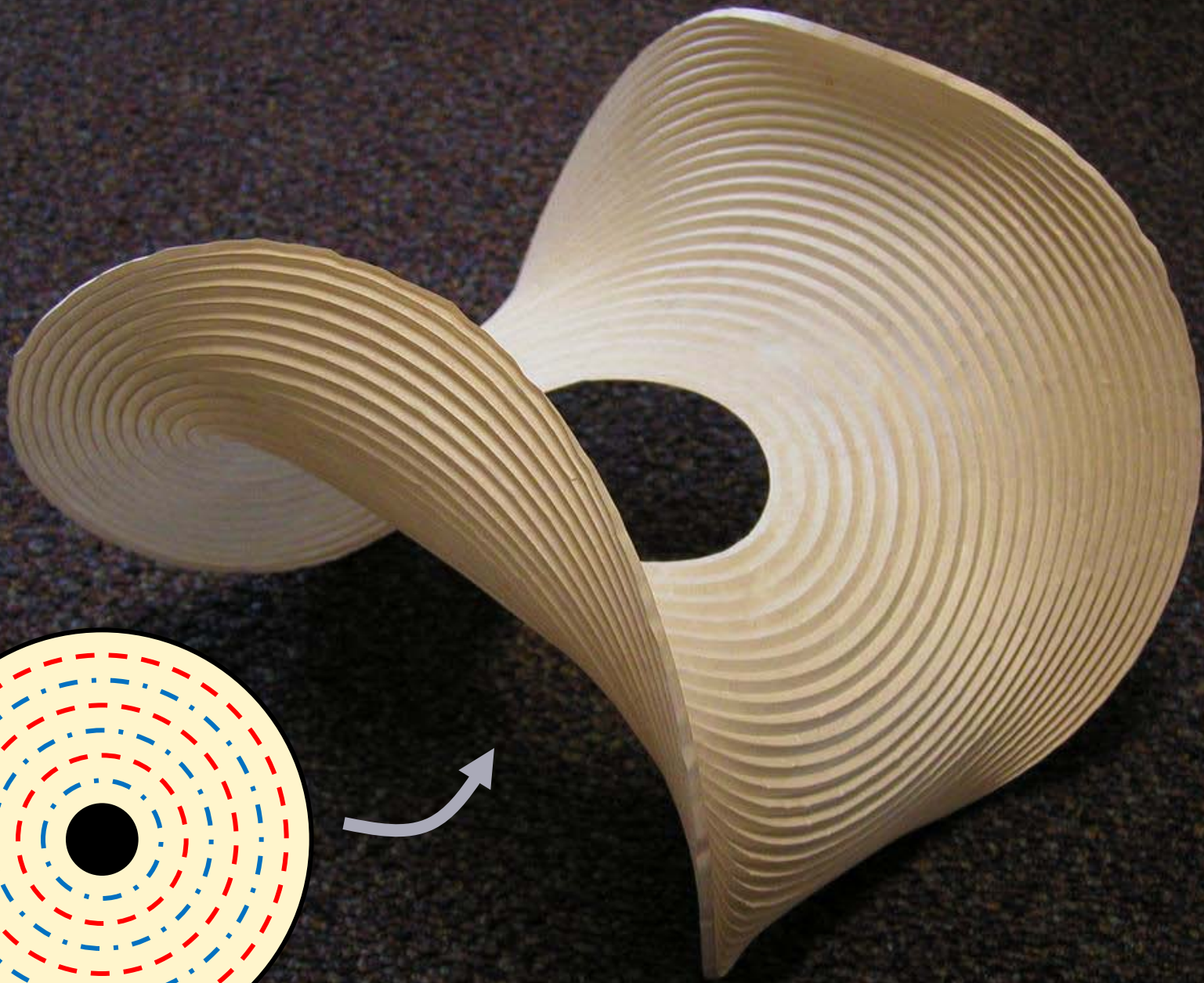

[Albers at Bauhaus, 1927-1928]

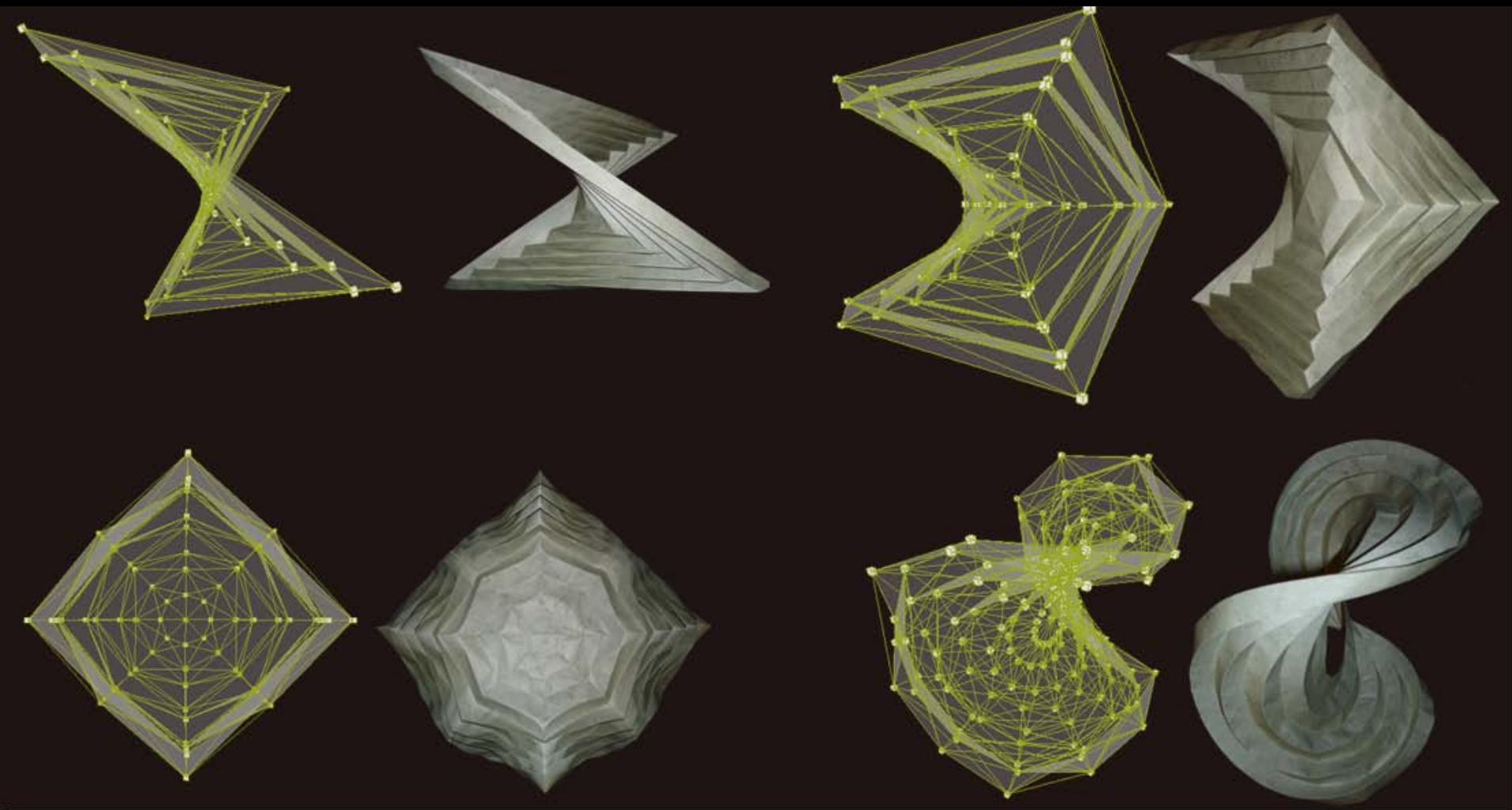

Virtual Origami
Demaine, Demaine, Fazel, Ochsendorf 2006



- 6 sides
- 15 folds
- 30 scale

piece
solid
free-form
tools
view

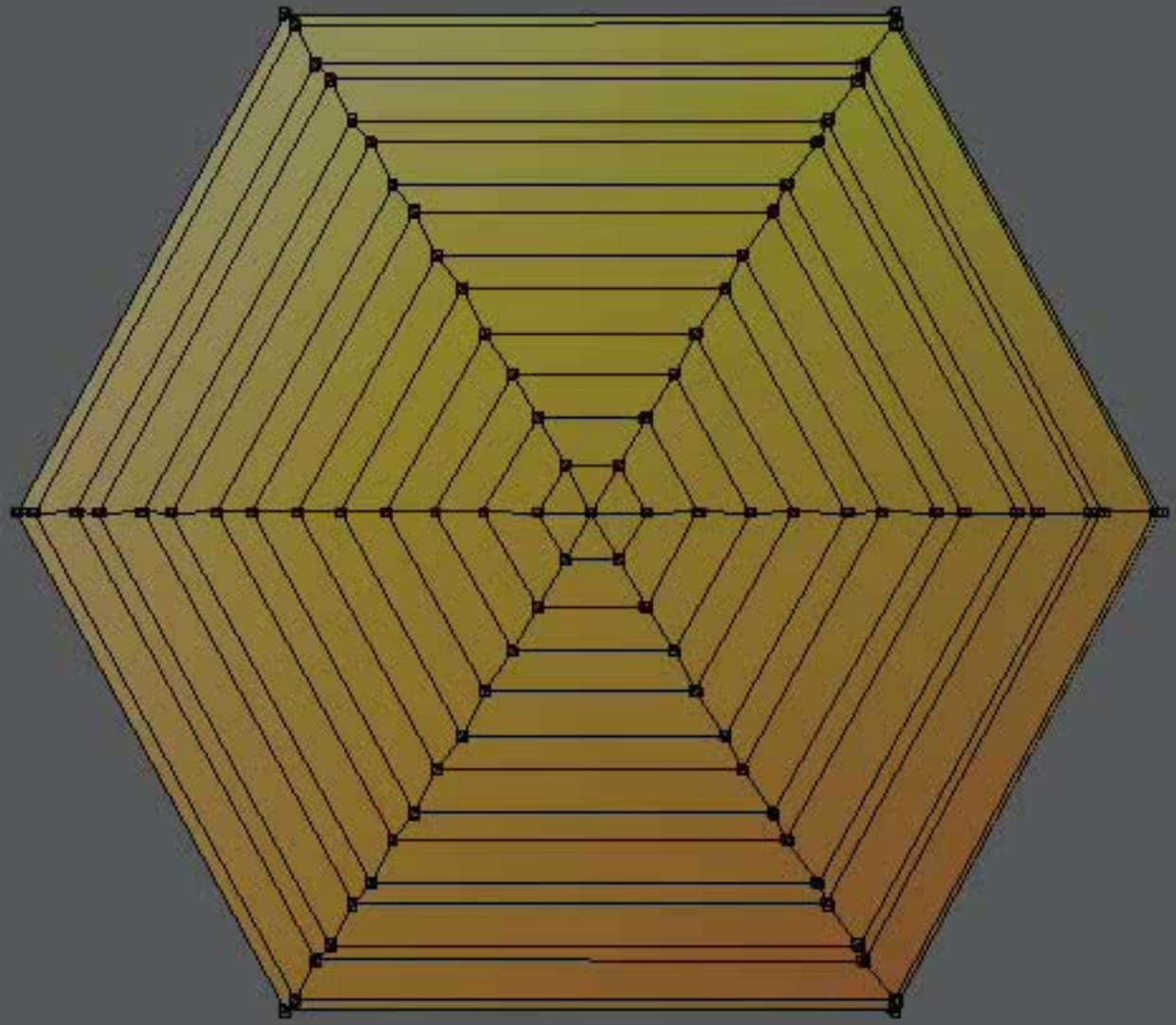

Virtual Origami

Demaine, Demaine, Fazel, Ochsendorf 2006

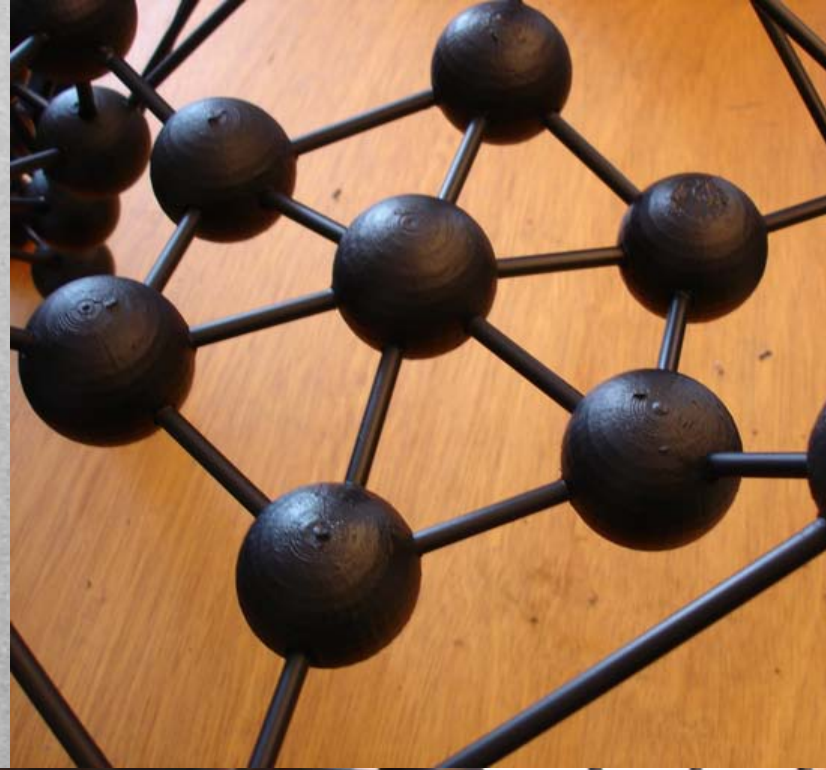
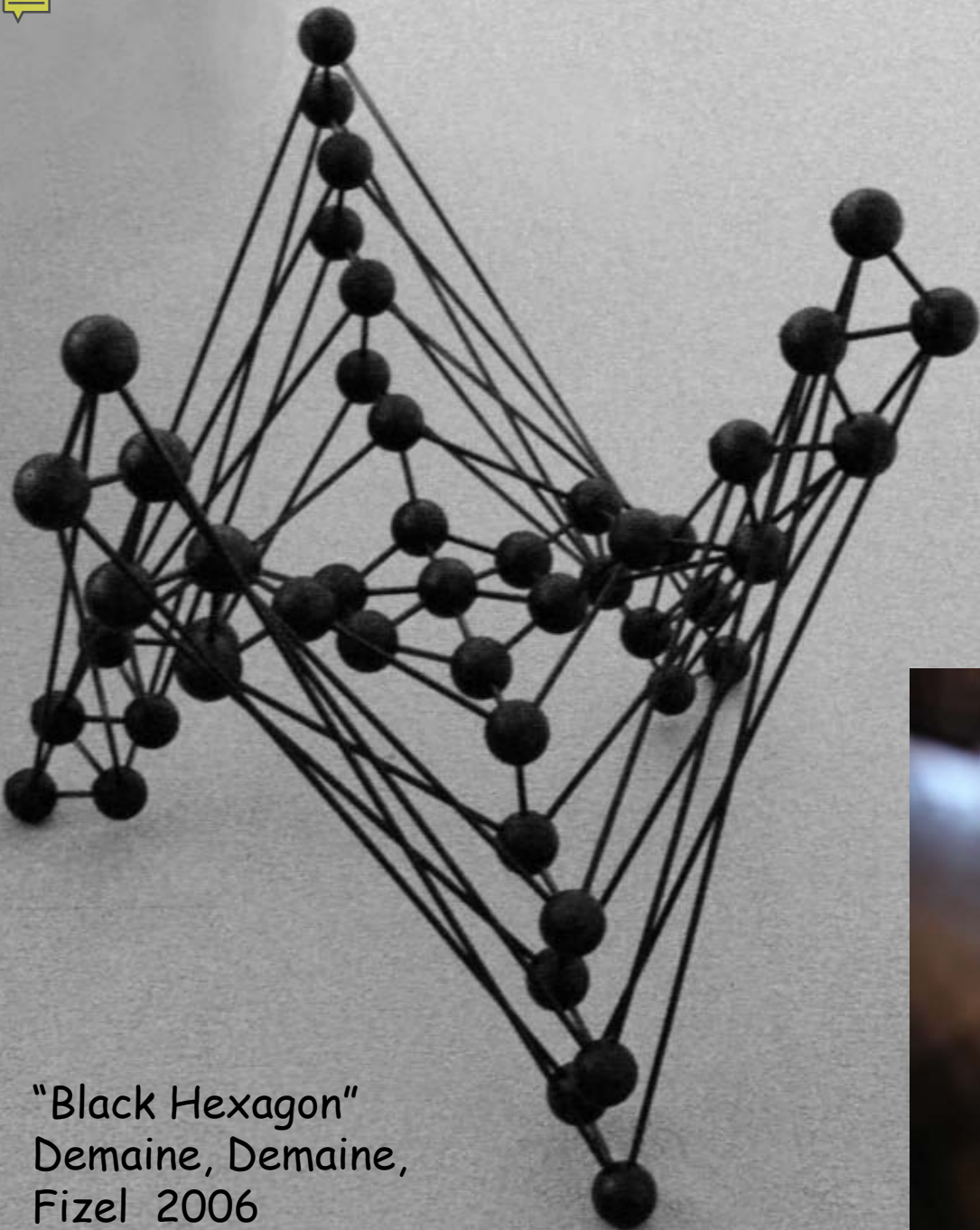

"Black Hexagon"
Demaine, Demaine,
Fizel 2006

Hyparhedra: Platonic Solids

[Demaine, Demaine, Lubiw 1999]

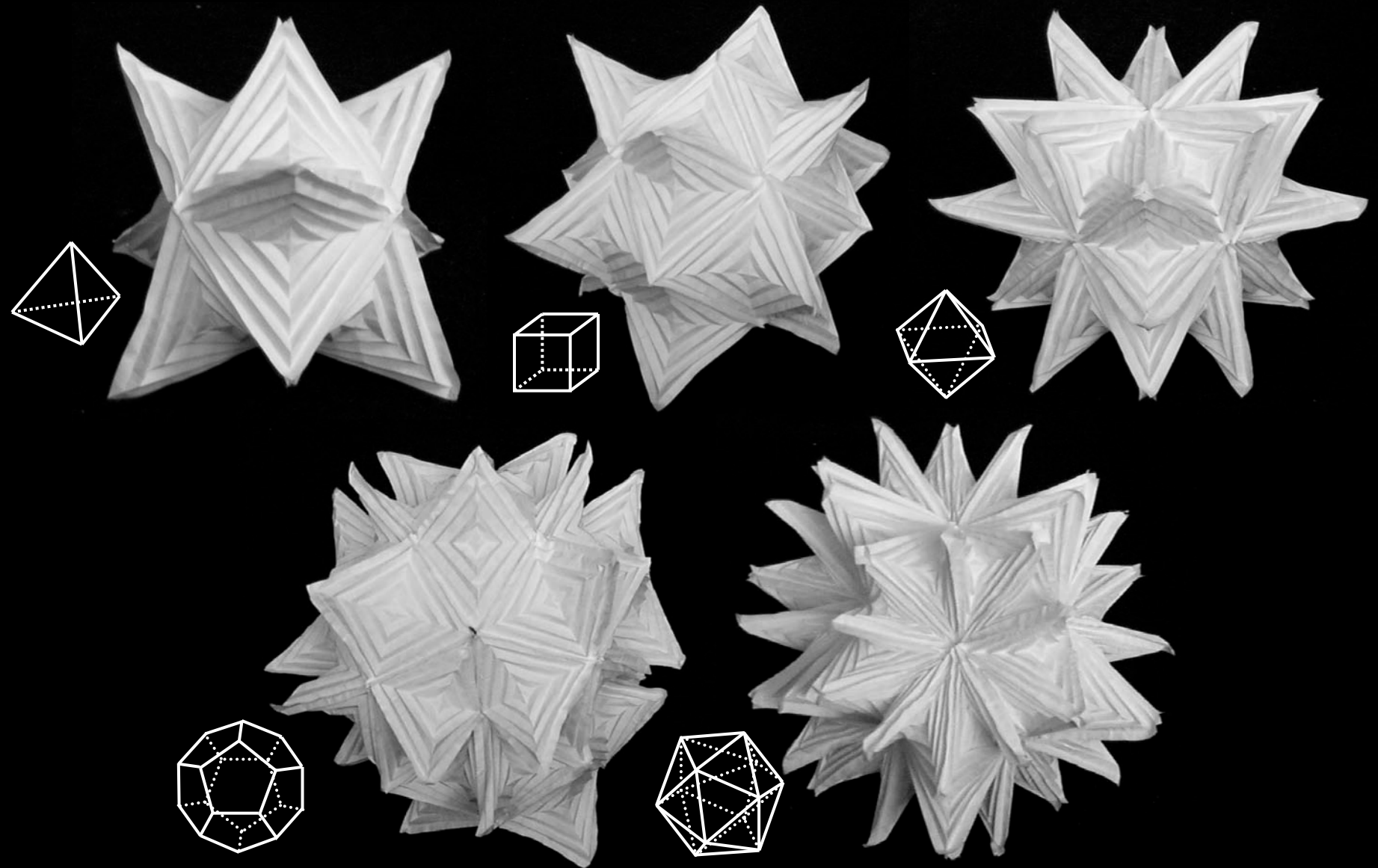

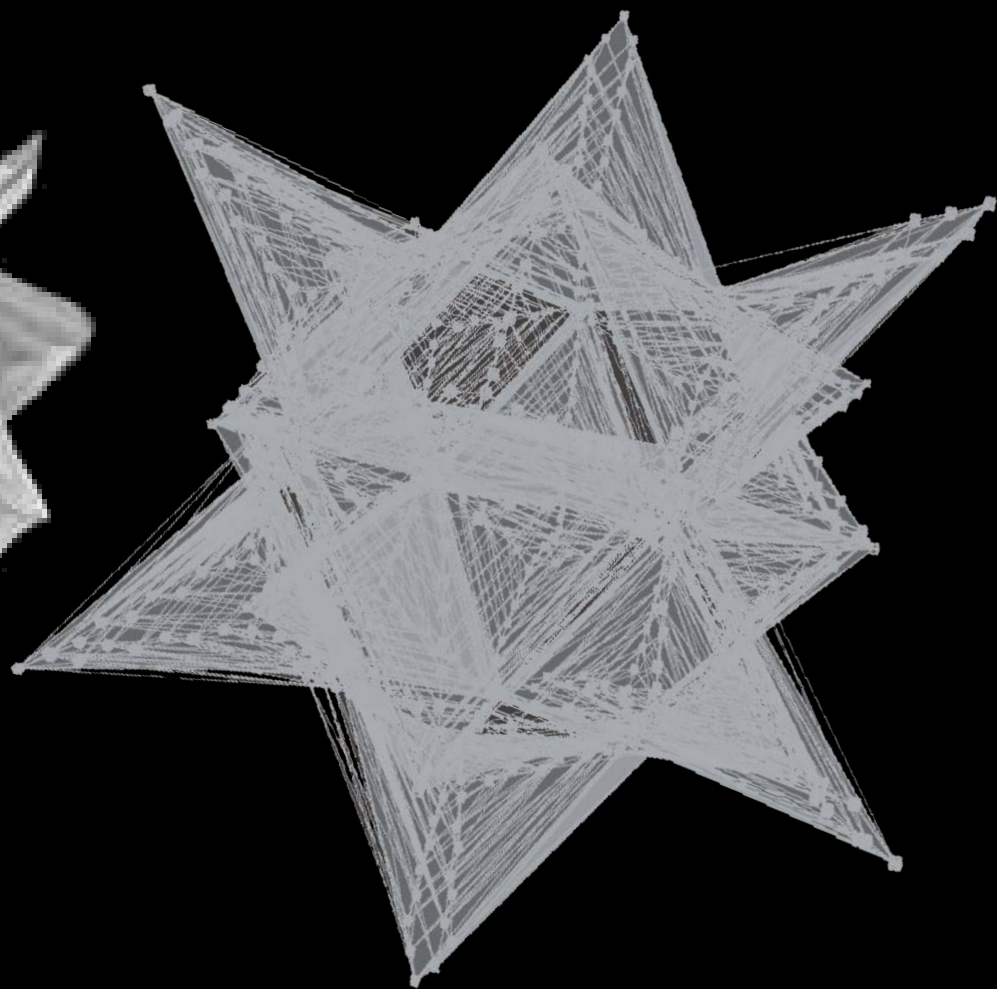

Virtual Origami

Demaine, Demaine, Fazel, Ochsendorf 2006



"Computational Origami"
Erik & Martin Demaine
MoMA, 2008-

Elephant hide paper
~9"x15"x7"



Peel Gallery, Houston

Nov. 2009

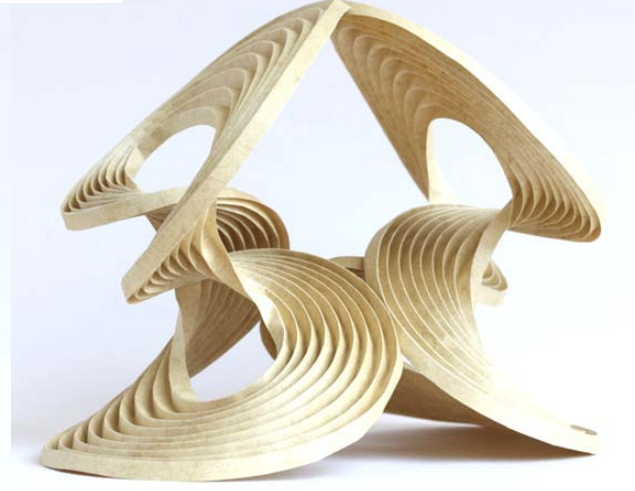

Demaine & Demaine 2009



"Natural Cycles"
Erik & Martin Demaine

JMM Exhibition of
Mathematical Art,
San Francisco, 2010



Waves in Glass

Erik Demaine
Martin Demaine



communication between glass & paper

Demaine & Demaine 2010

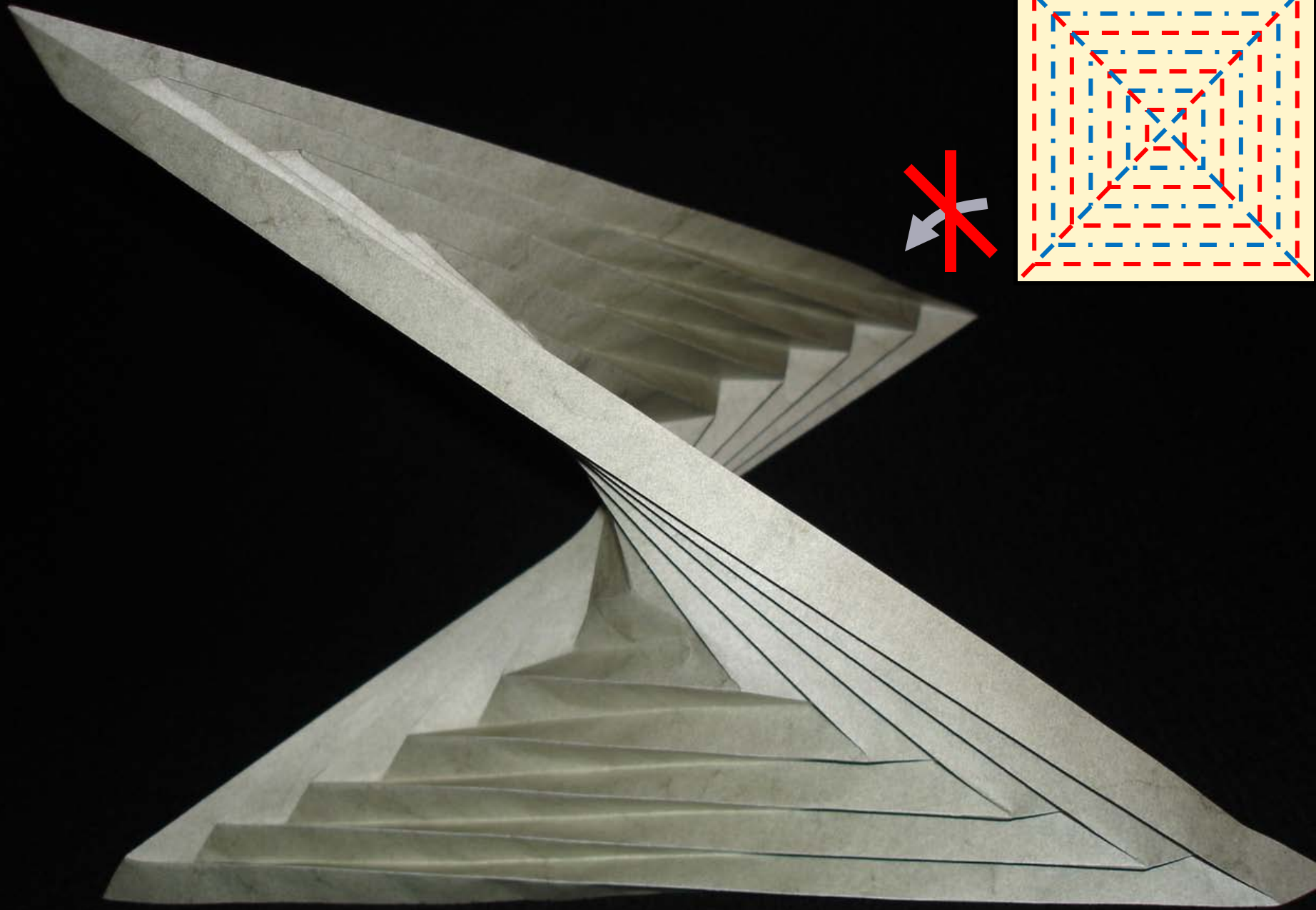

[Demaine, Demaine, Hart, Price, Tachi 2009/2010]

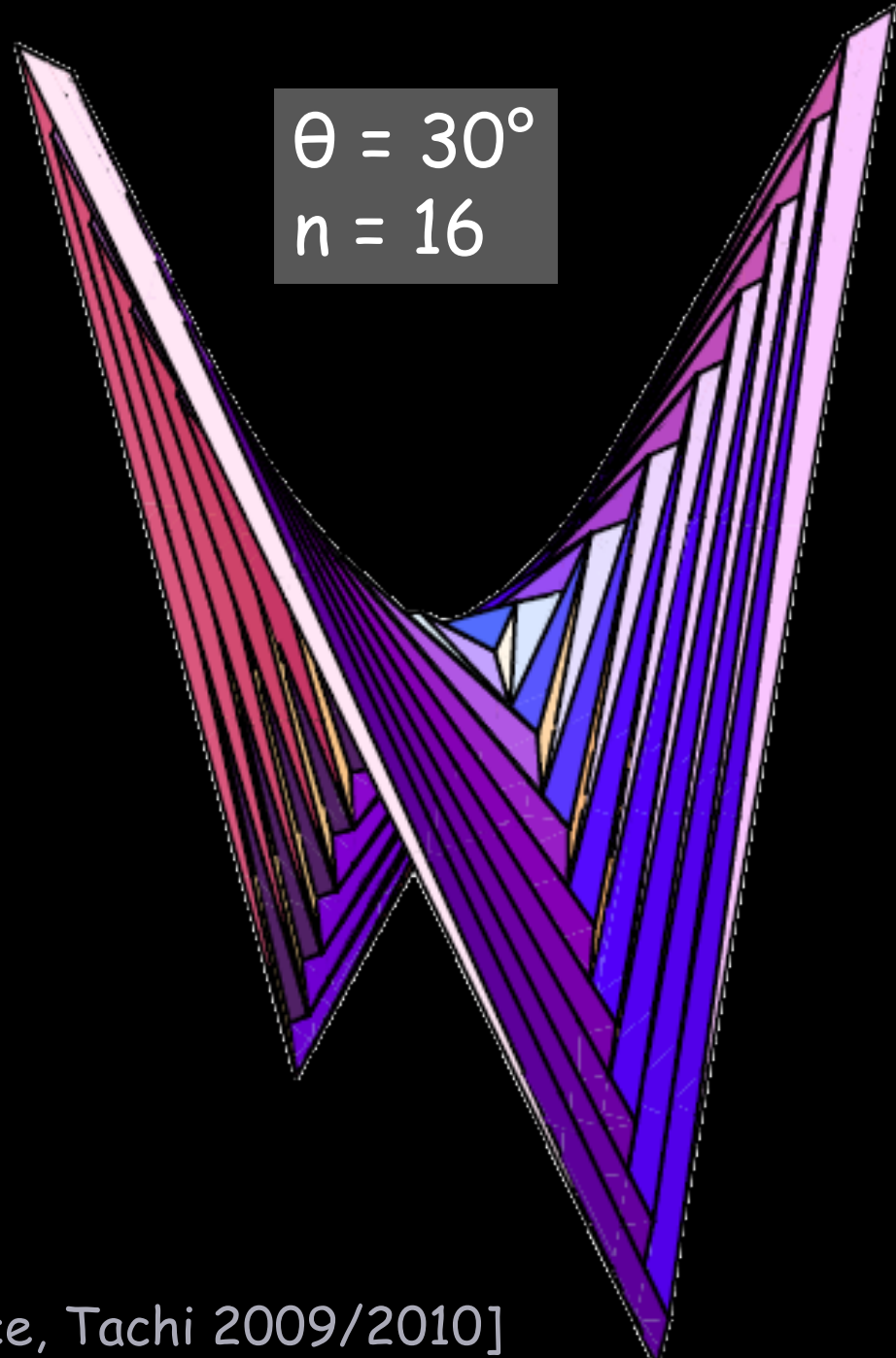
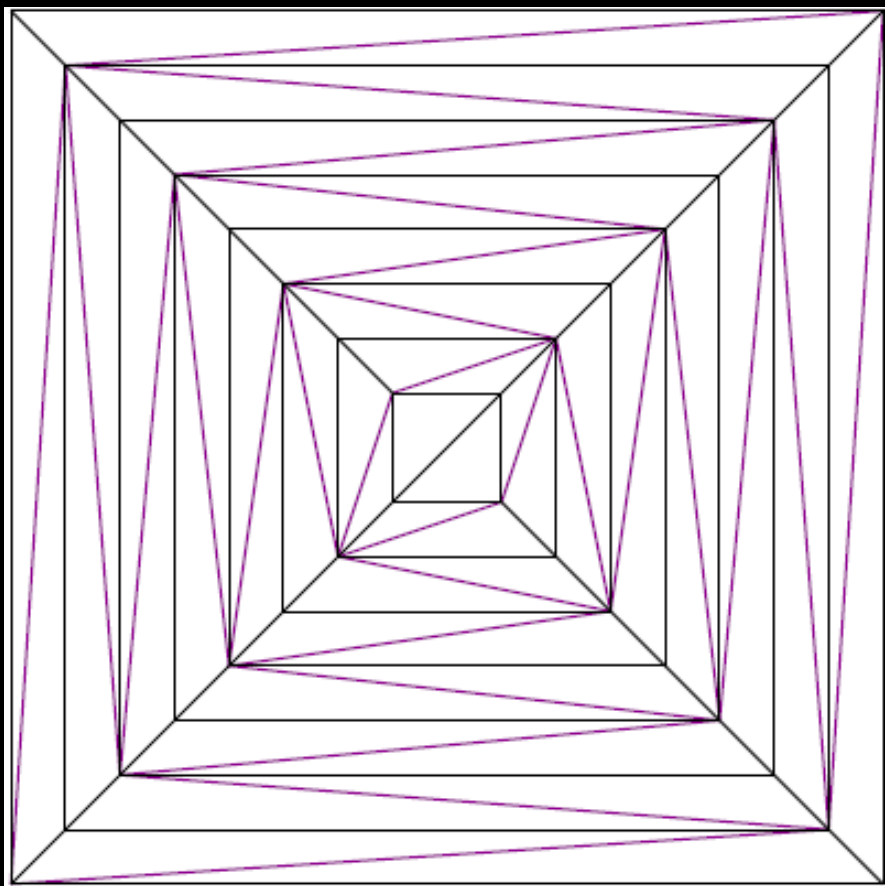

[Demaine, Demaine, Hart, Price, Tachi 2009/2010]



[Demaine,
Demaine,
Hart, Price,
Tachi
2009/2010]

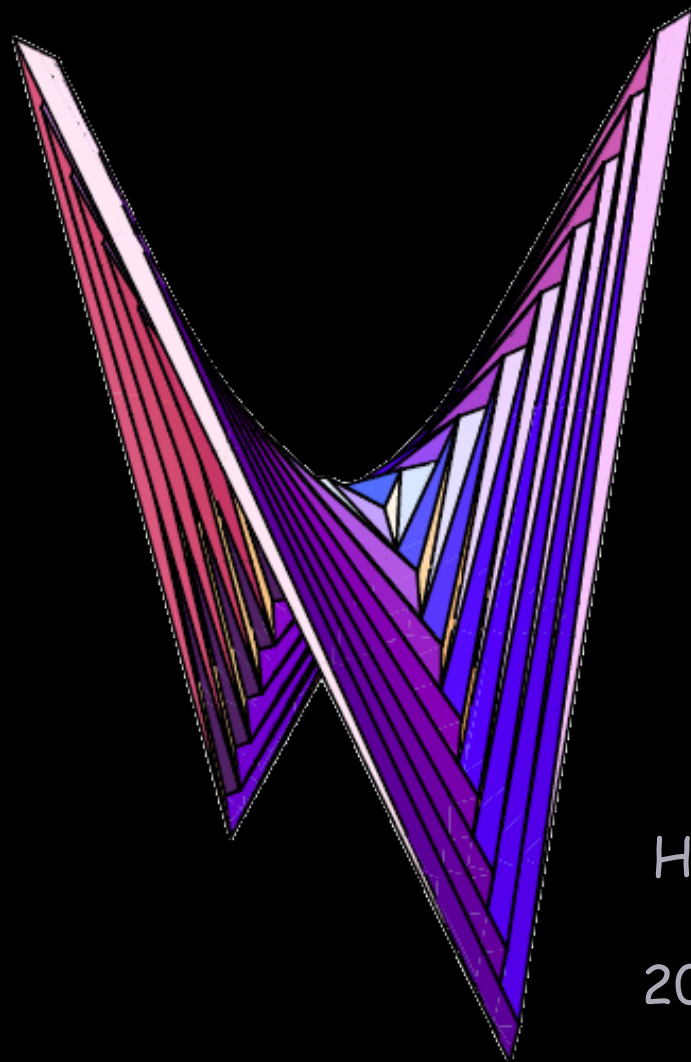
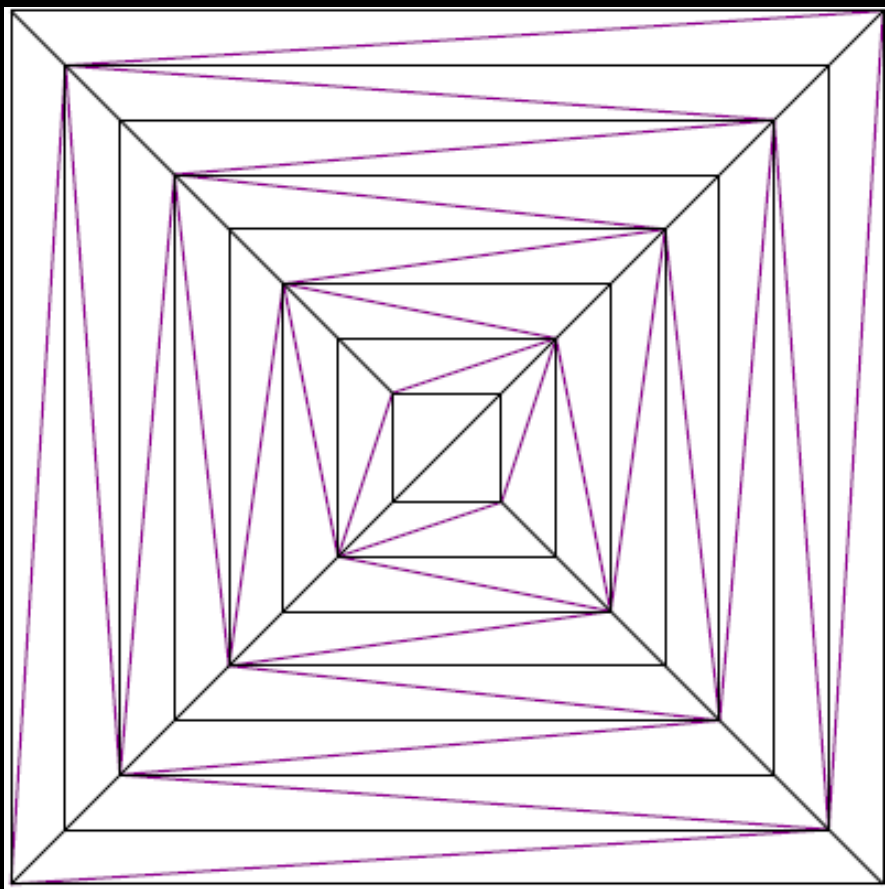

[Demaine,
Demaine,
Hart, Price,
Tachi
2009/2010]

digits of precision	16	32	64	128	256	512	1024	2048
n for $\theta = 1^\circ$ alt.	3	6	12	24	43	79	≥ 100	
n for $\theta = 45^\circ$ alt.	3	5	10	18	32	58	≥ 100	
n for $\theta = 76^\circ$ alt.	2	5	9	16	29	53	95	≥ 100

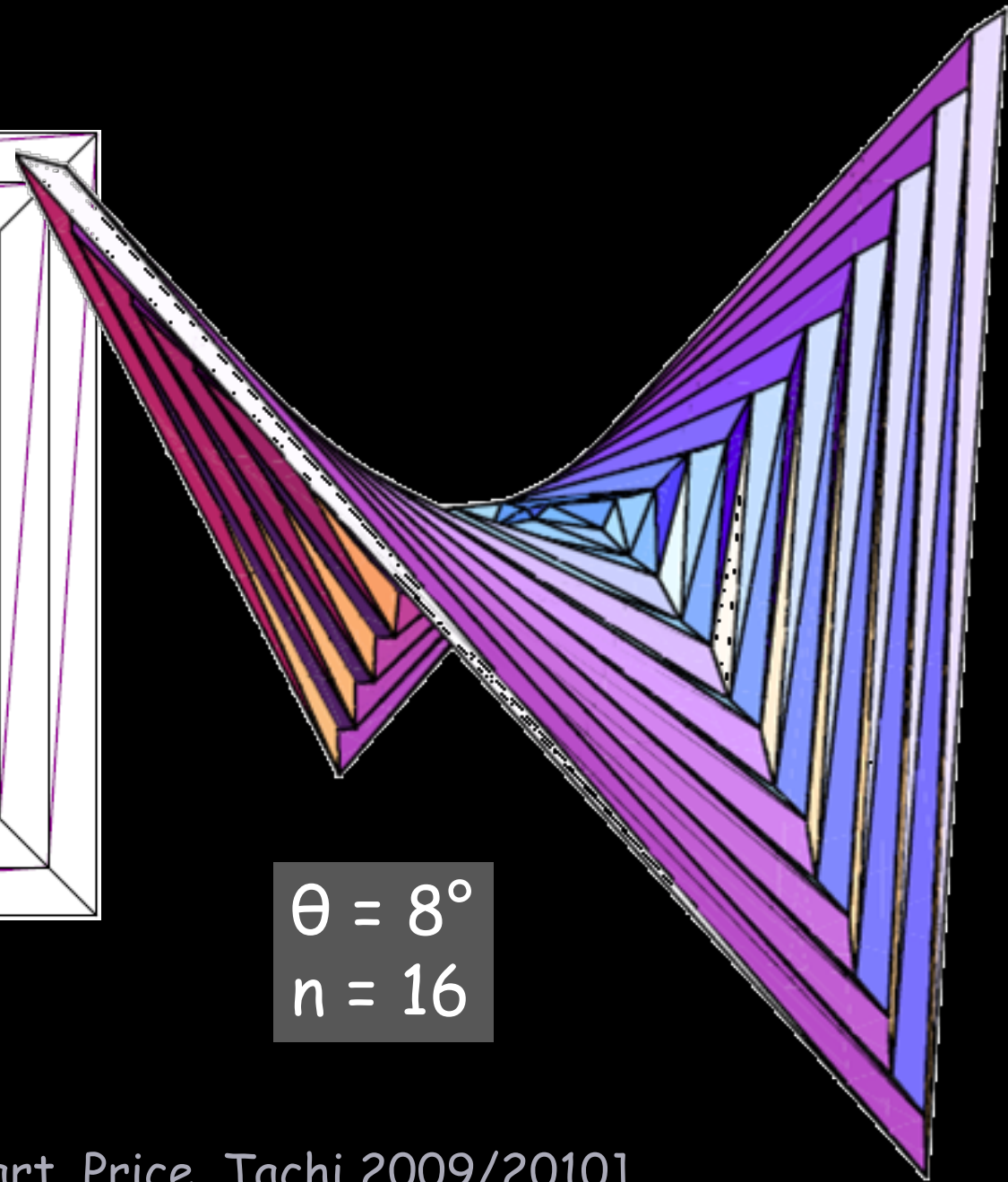
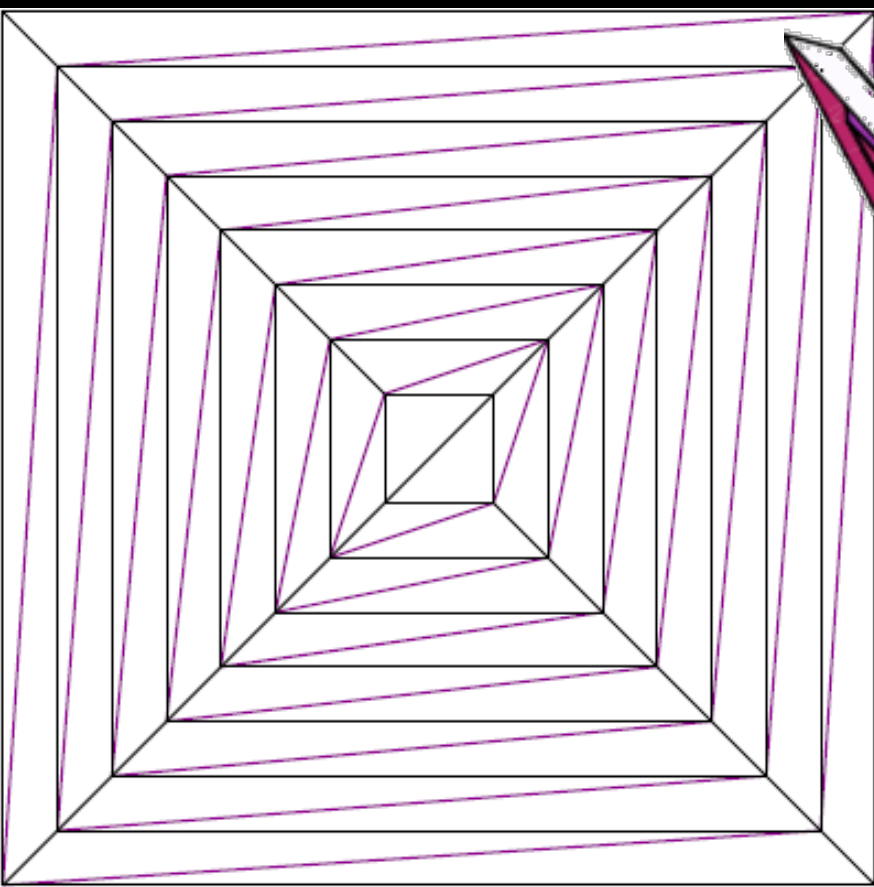

$\theta = 8^\circ$
 $n = 16$

[Demaine, Demaine, Hart, Price, Tachi 2009/2010]

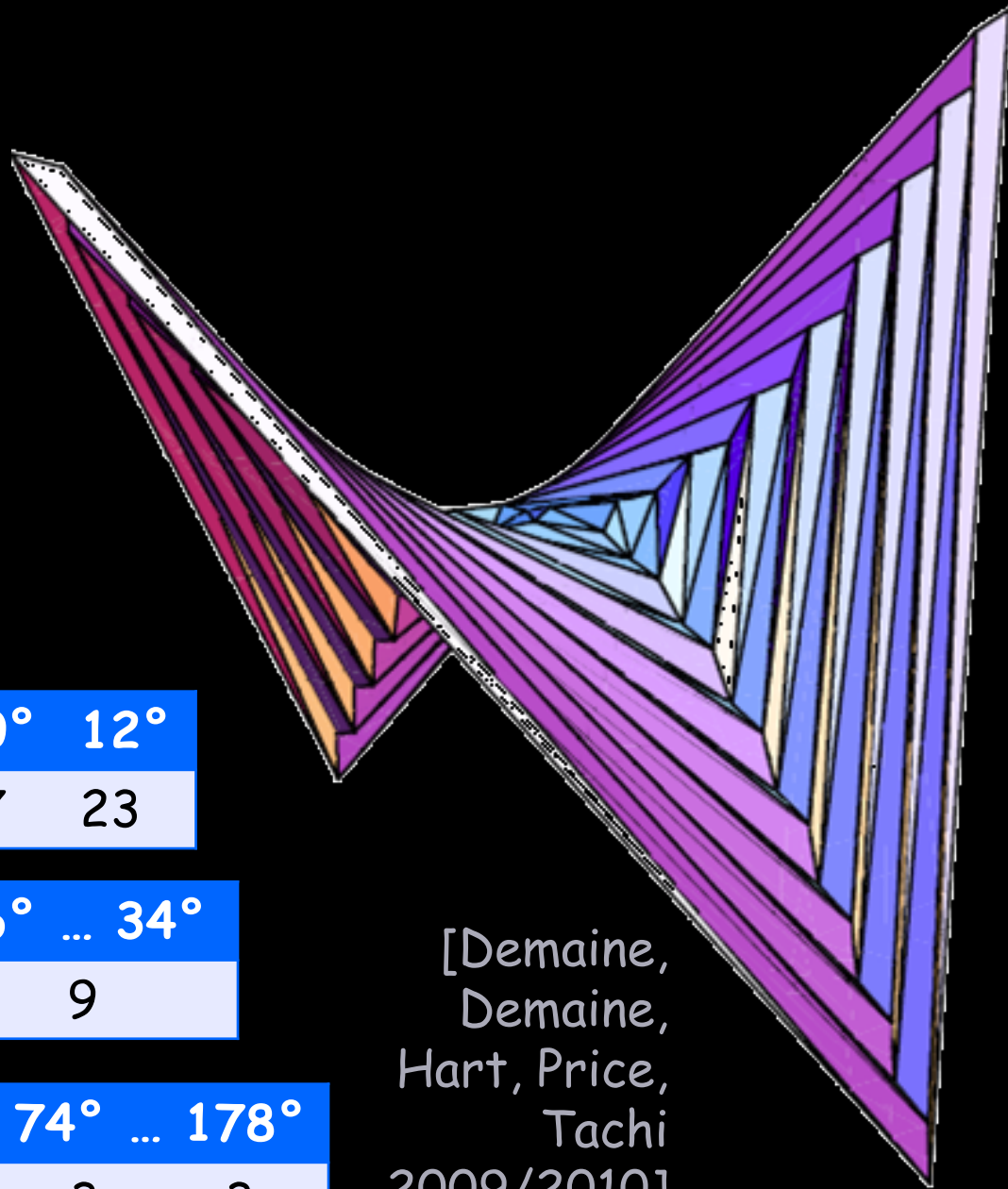
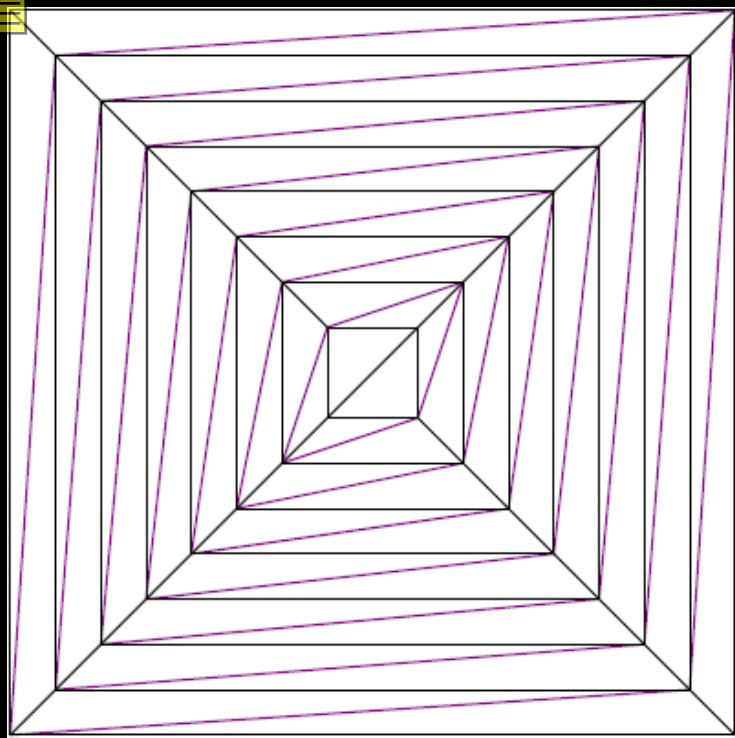

$\theta =$	2°	4°	6°	8°	10°	12°
$n \leq$	133	67	45	33	27	23

$\theta =$	18°	20°	22°	24°	26°	...	34°
$n \leq$	15	13	13	11			9

$\theta =$	36°	...	46°	48°	...	72°	74°	...	178°
$n \leq$	7	...	7	5	...	5	3	...	3

[Demaine,
Demaine,
Hart, Price,
Tachi
2009/2010]

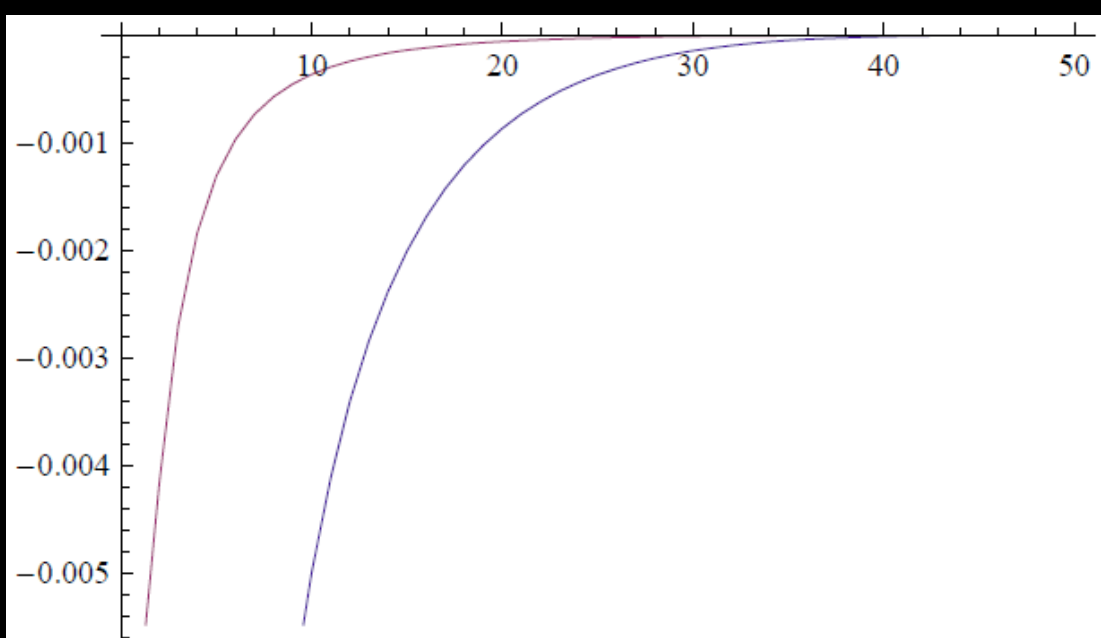
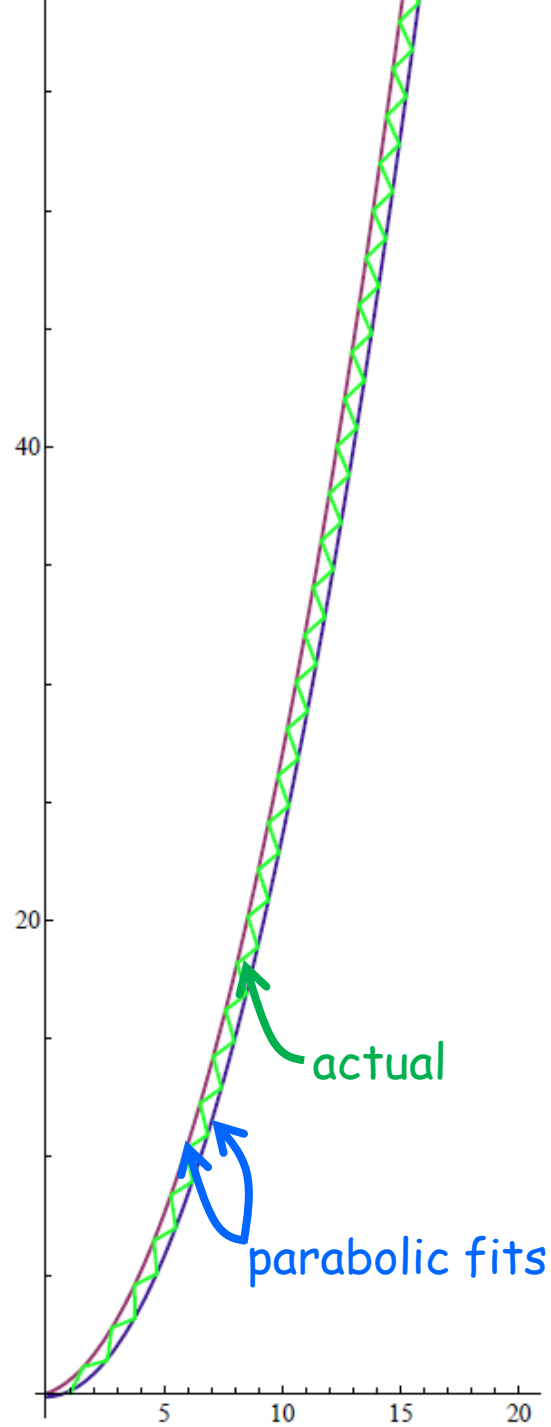

(b) Absolute difference: fit minus actual.

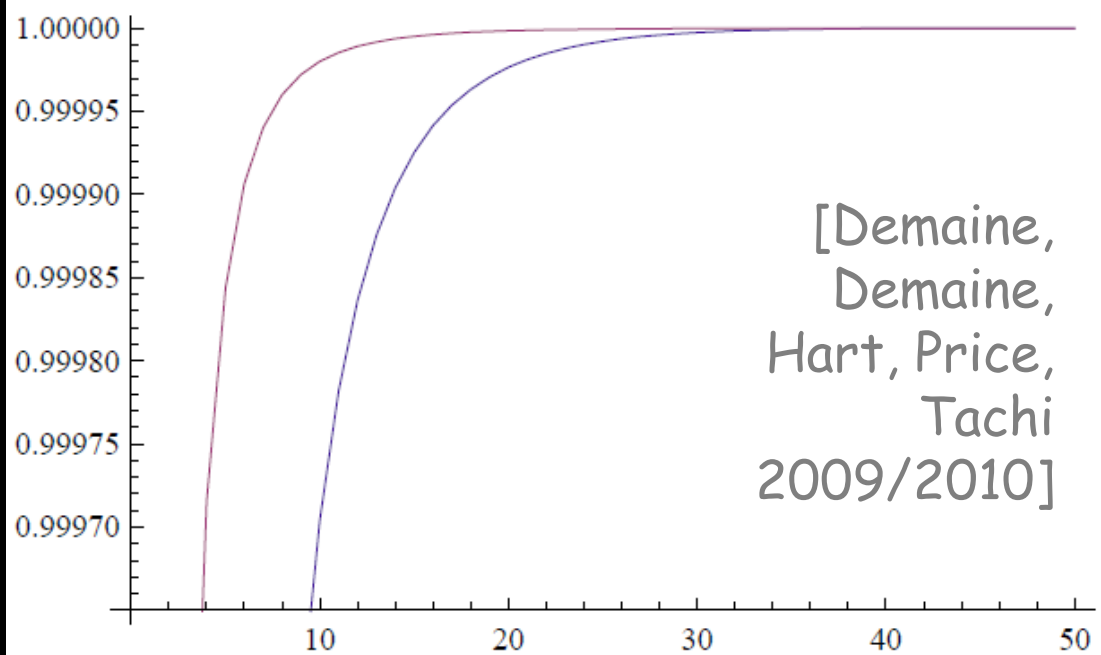

(c) Relative difference: fit over actual.

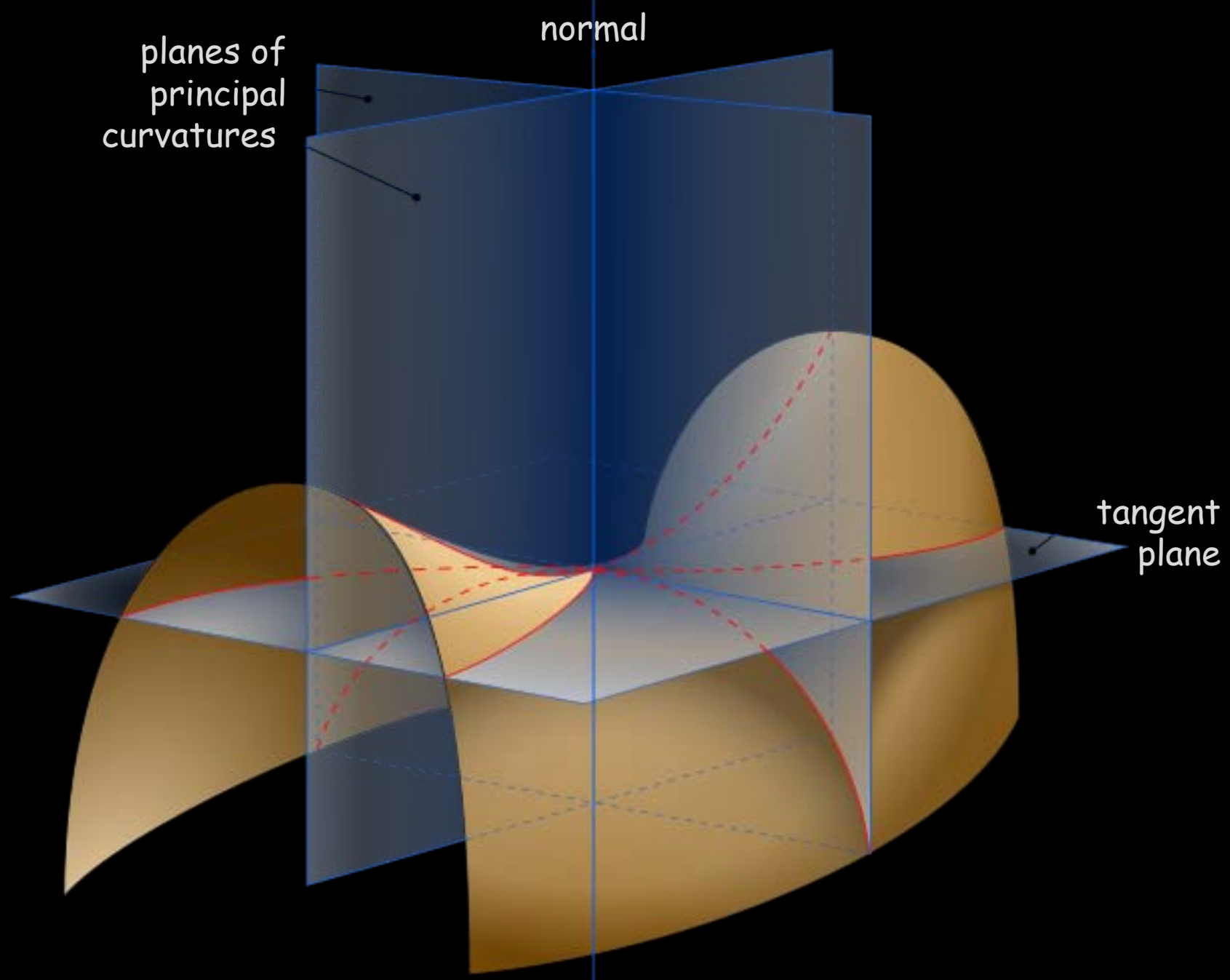

figure by Eric Gaba licensed under Creative Commons Attribution-Share Alike 3.0 Unported



photo by William McCallum licensed under Creative Commons Attribute-Share Alike 3.0

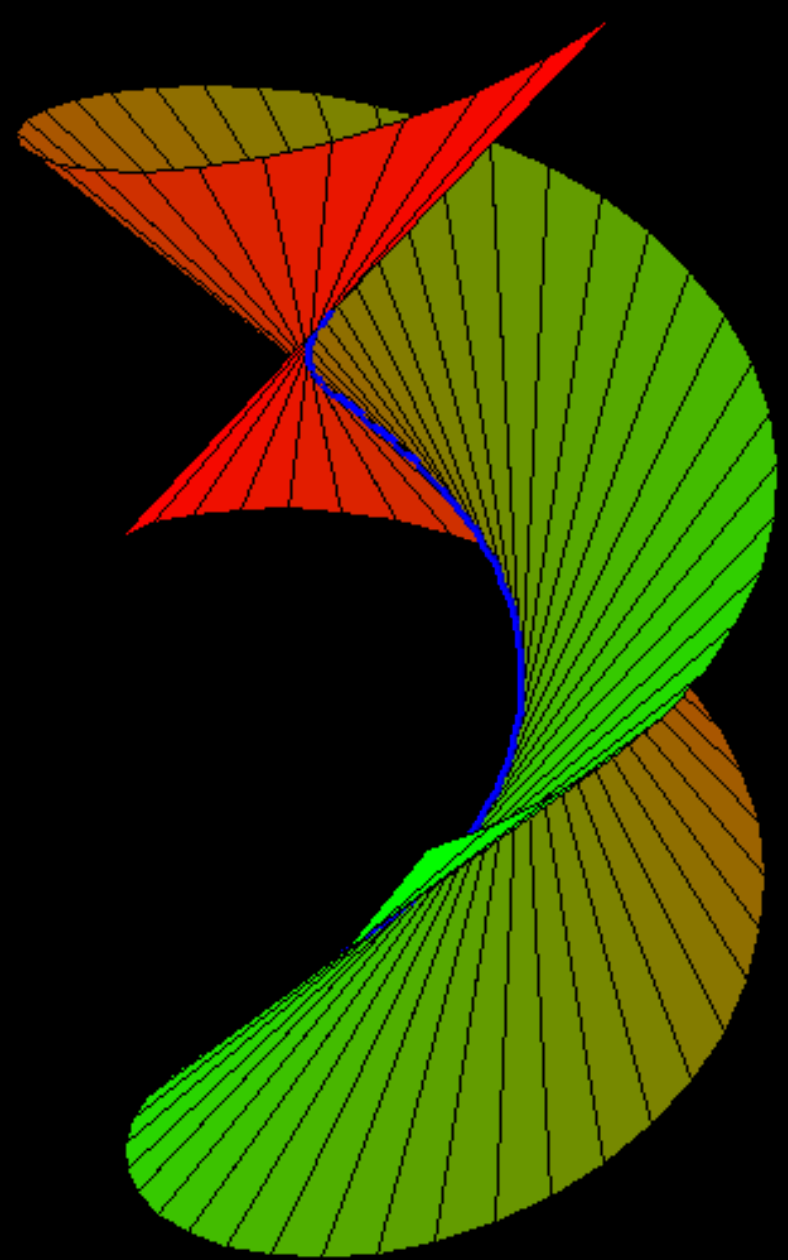
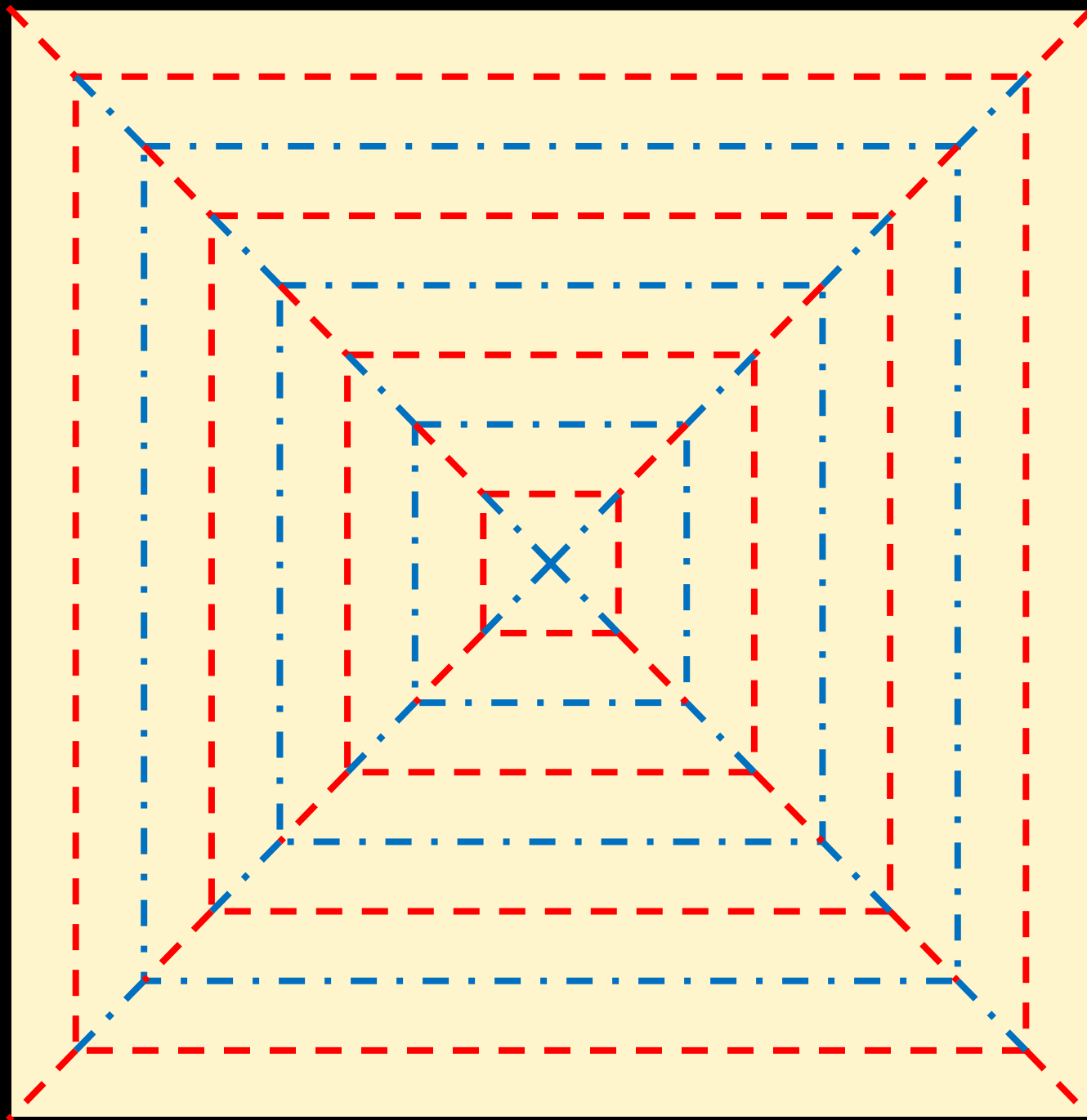
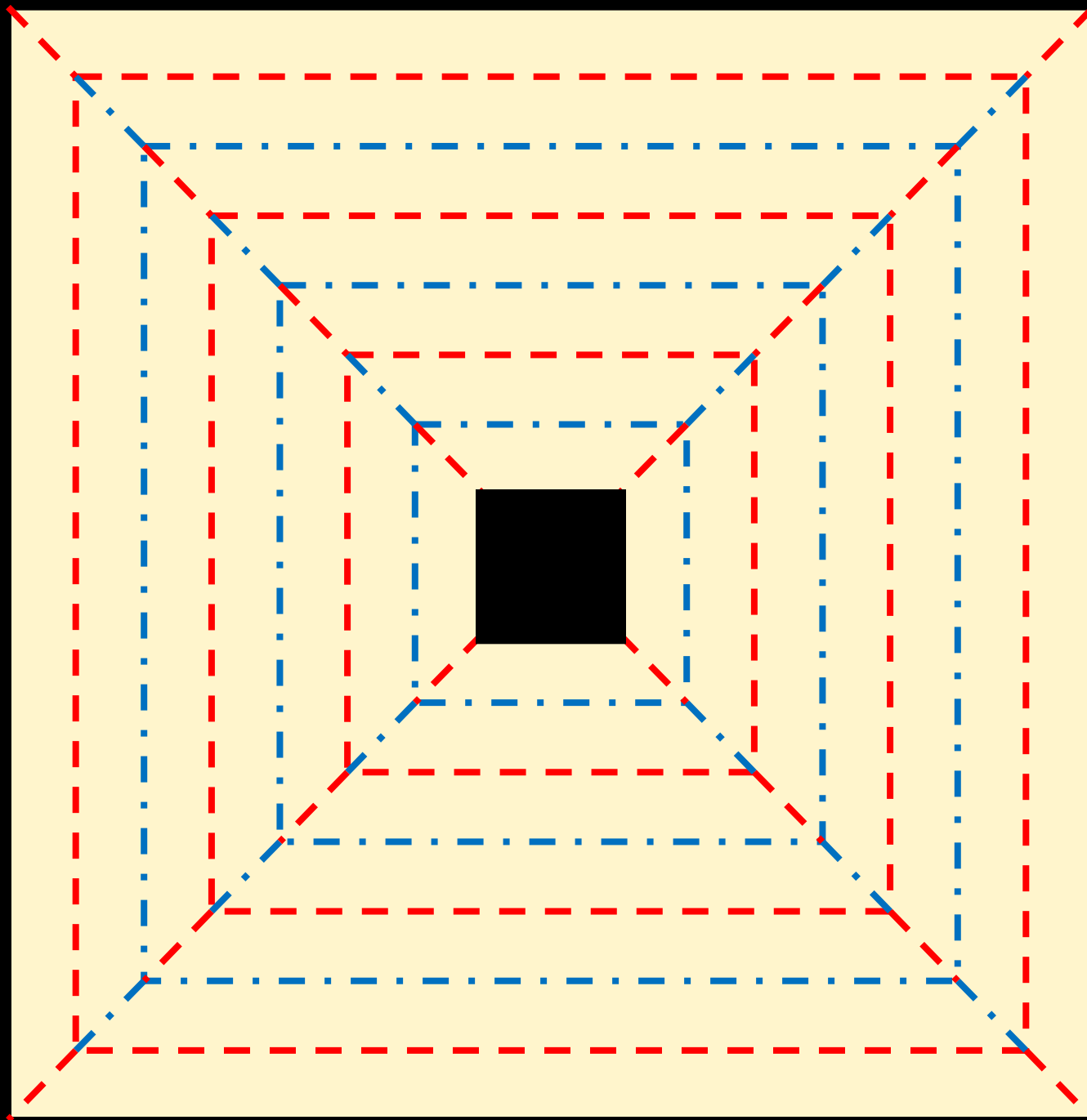

photo by Richard Morris licensed under Creative Commons Attribute-Share Alike 3.0



[Demaine,
Demaine,
Hart, Price,
Tachi
2009/2010]



[Demaine,
Demaine,
Hart, Price,
Tachi
2009/2010]

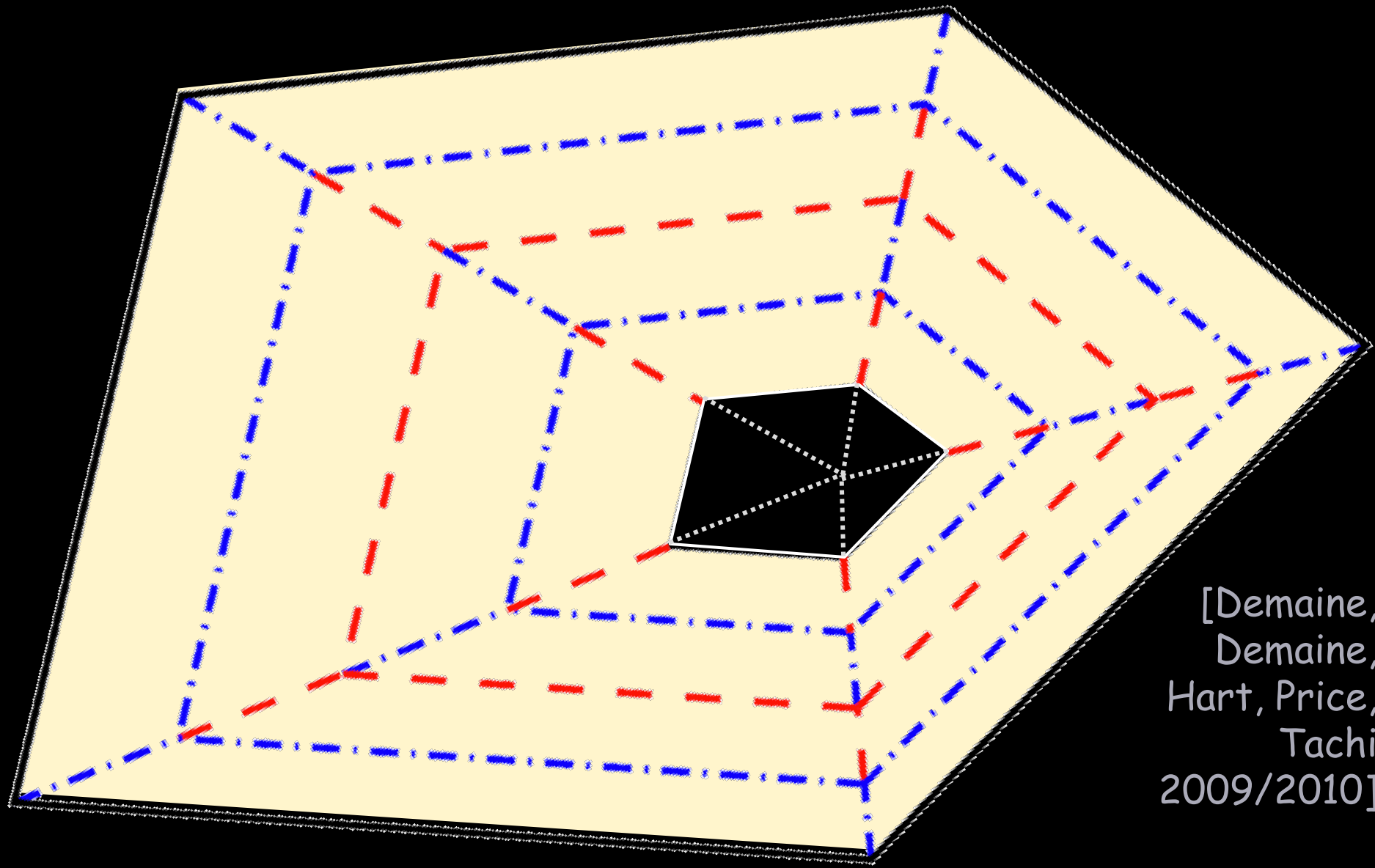

[Demaine,
Demaine,
Hart, Price,
Tachi
2009/2010]



photo by *Gina (gin_able)* licensed under
Creative Commons Attribution-NonCommercial 2.0 Generic



photo by green kozi licensed under
Creative Commons Attribution 2.0 Generic

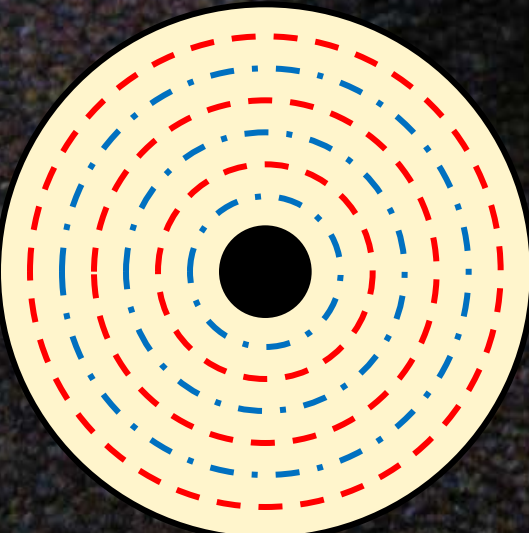
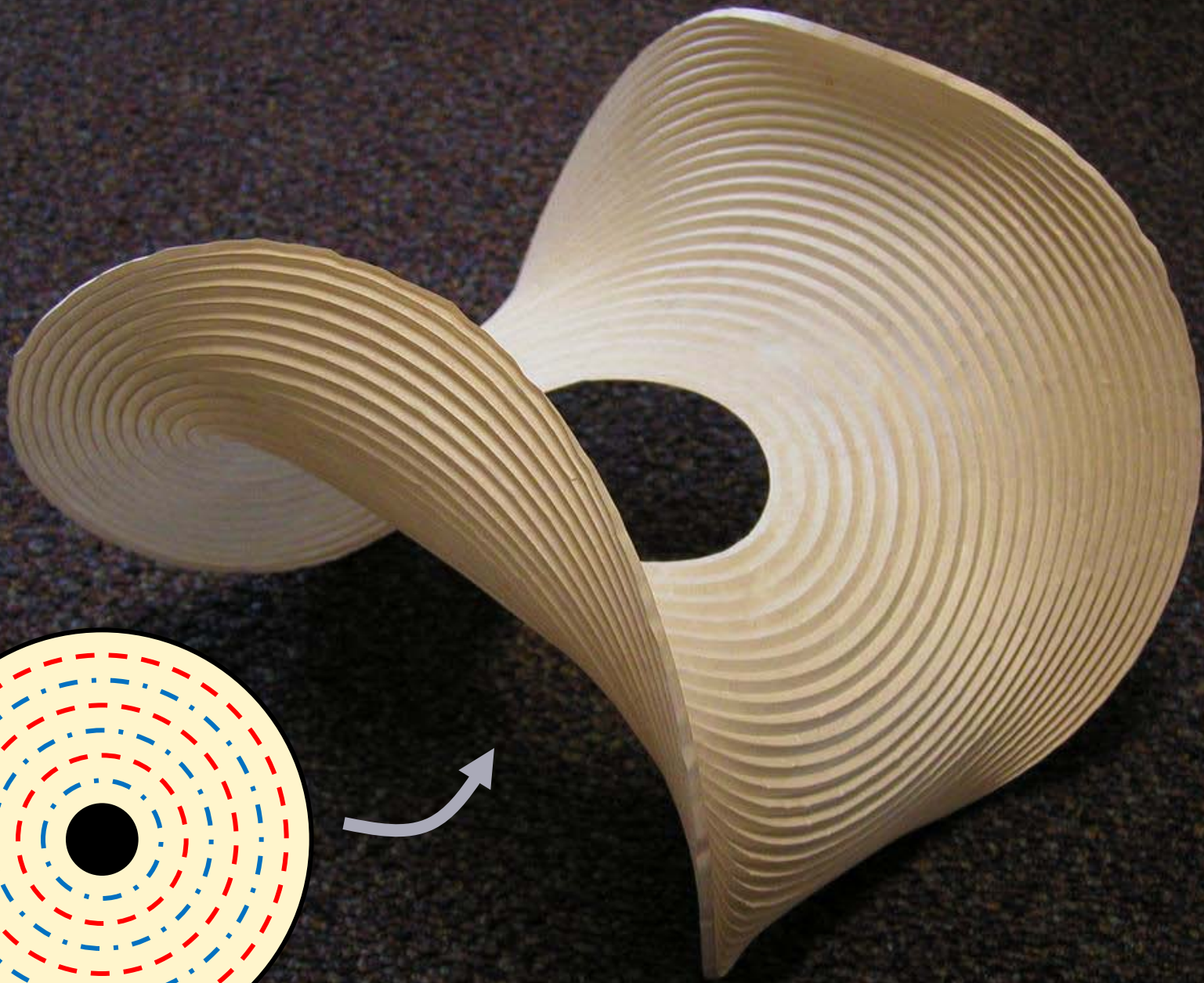

[Albers at Bauhaus, 1927-1928]

Huffman Family (May 2010)



Linda Marilyn Elise

Tessellations

circles

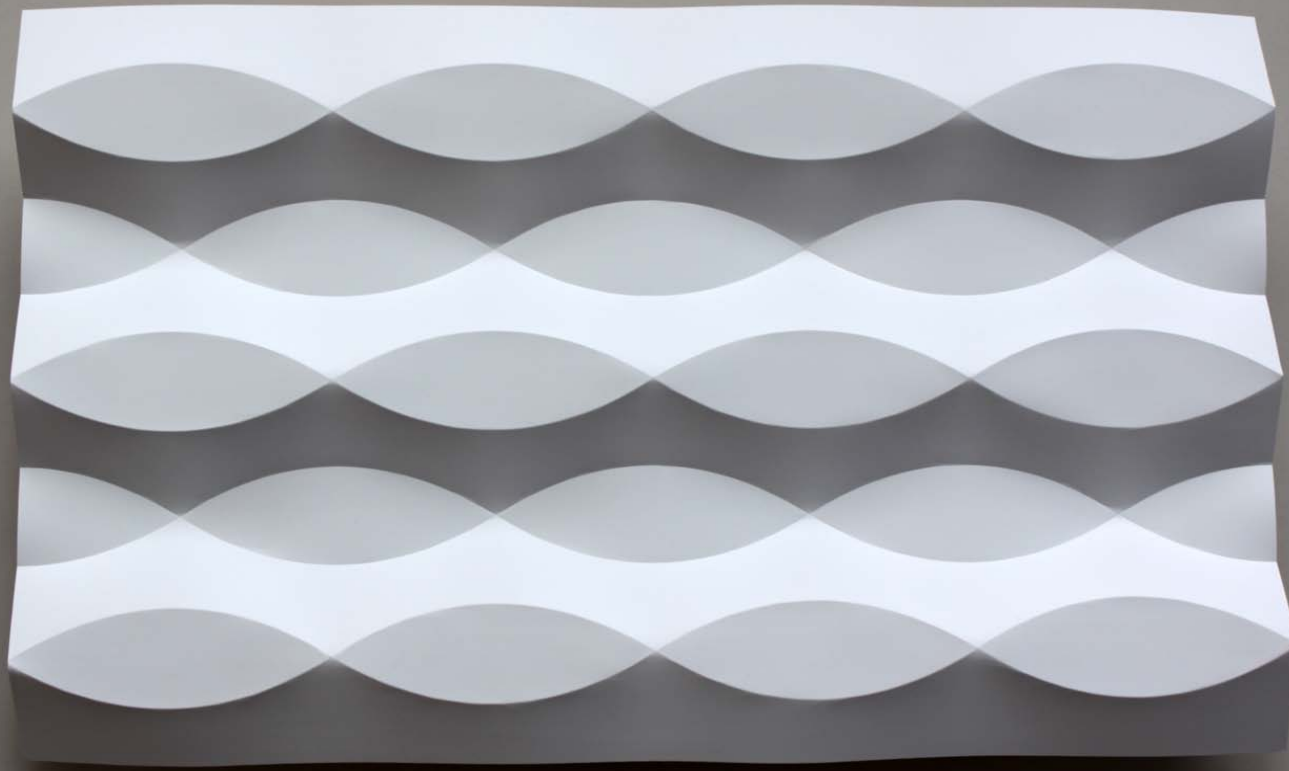
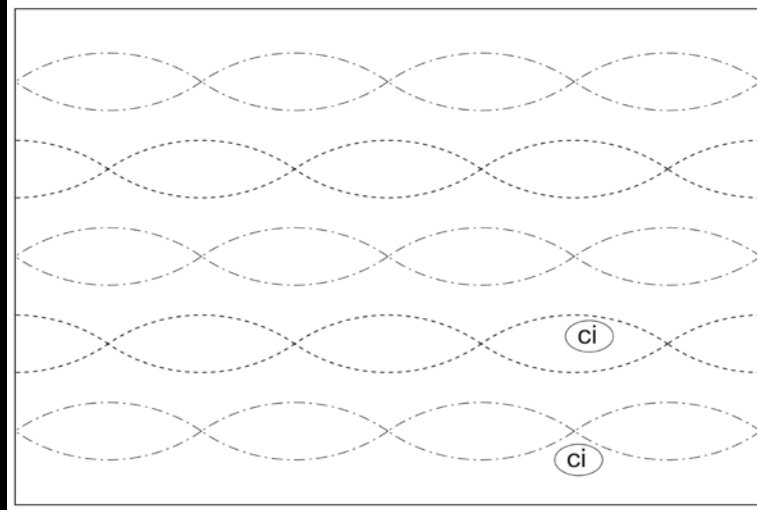

design by David Huffman; recreated folding by Demaine, Demaine, Koschitz 2010



Tessellations

"Arches"

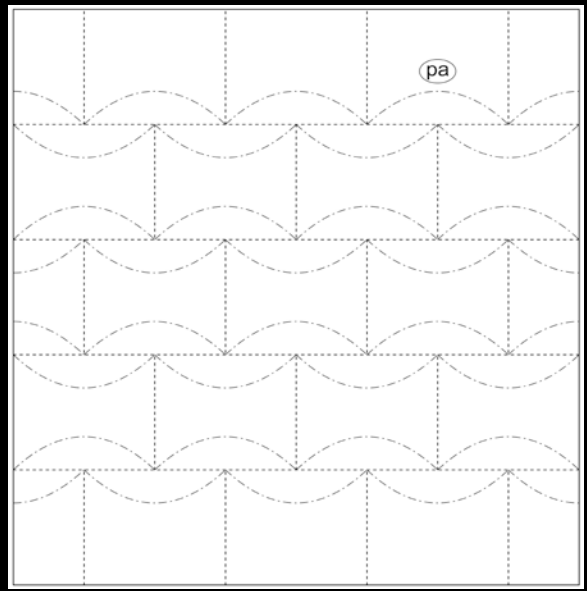

parabolas
& lines

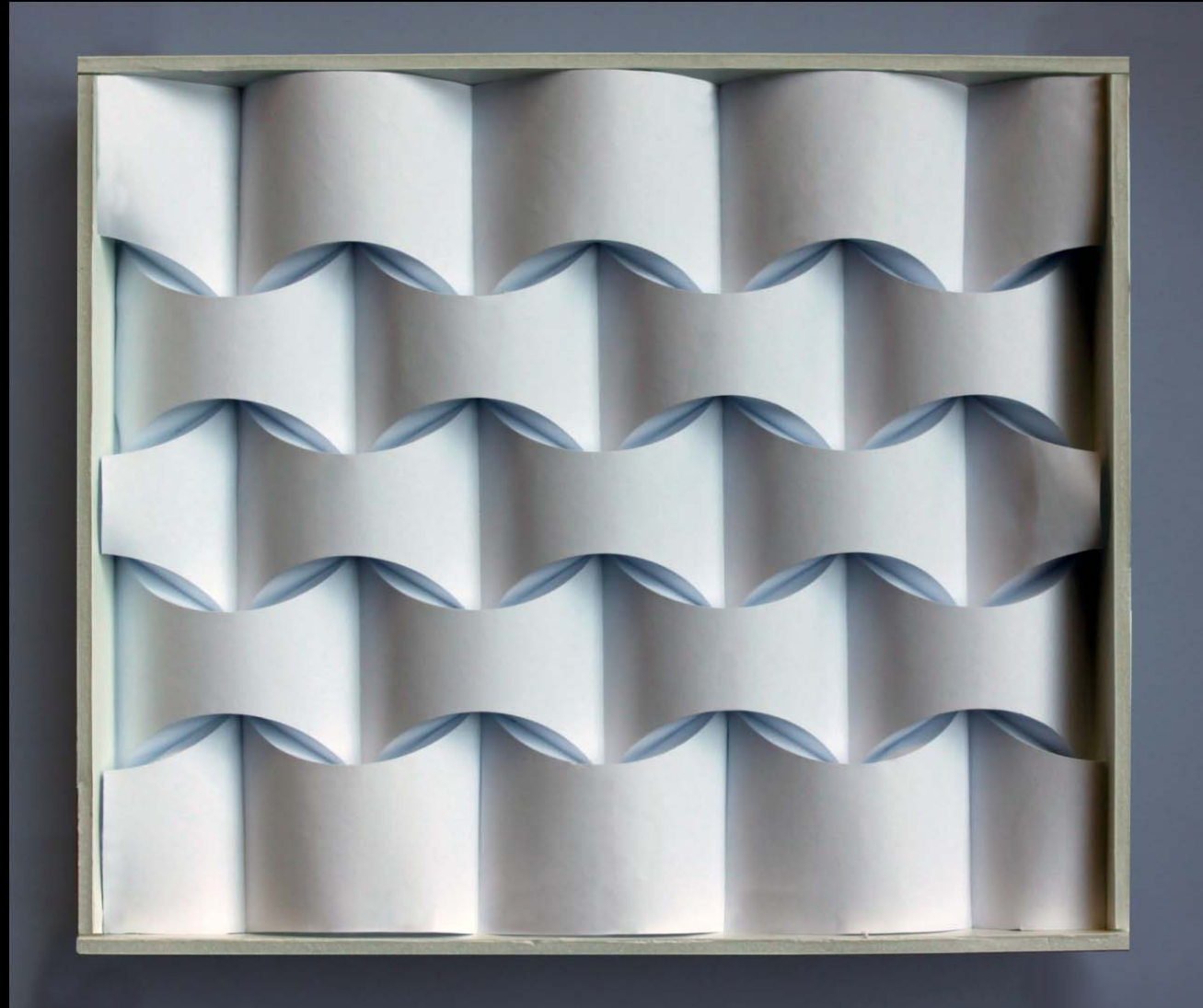

design by David Huffman; recreated folding by Demaine, Demaine, Koschitz 2010

🗨️ "Cone reflected 7 times"

circles & nonconics

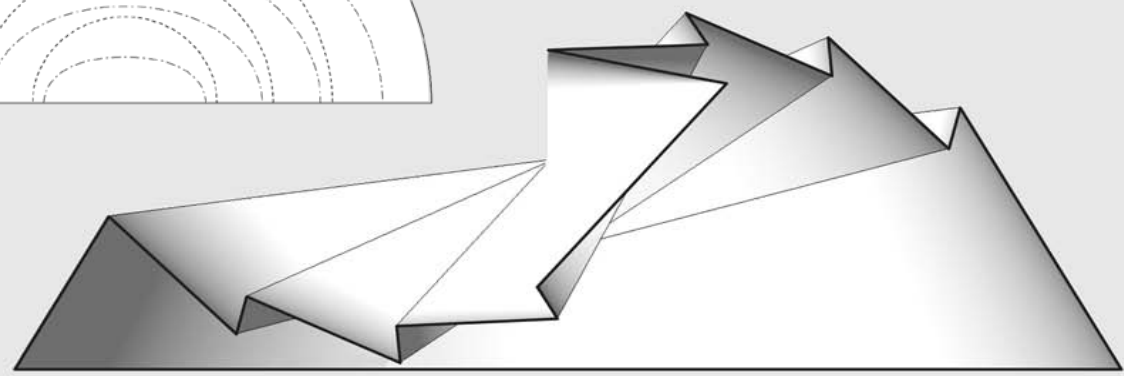
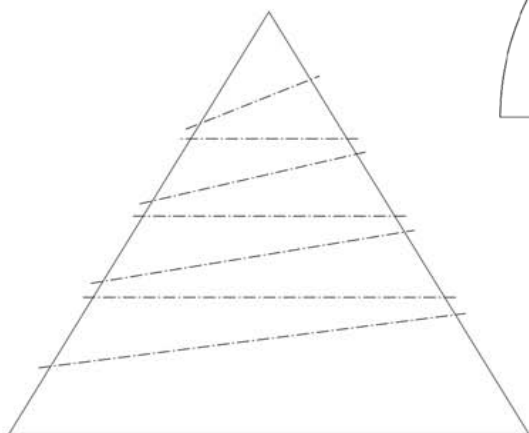
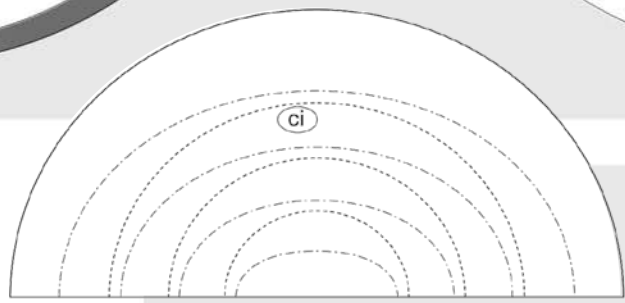
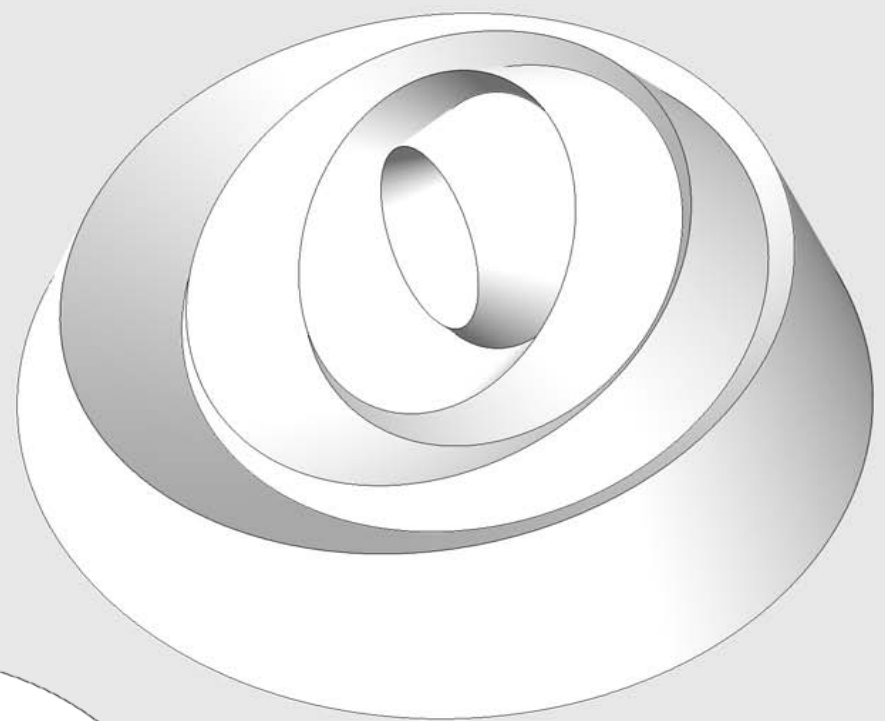
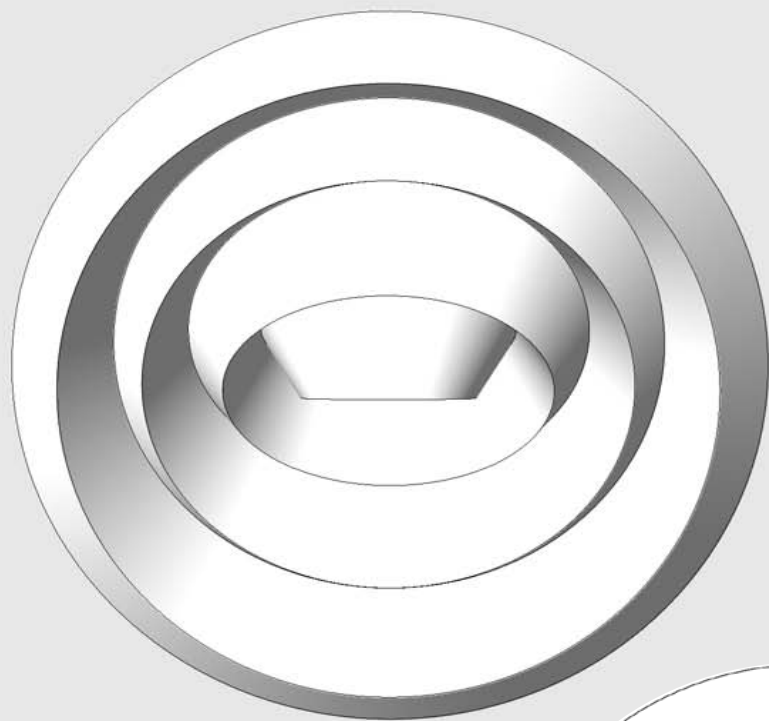

“Hexagonal column with cusps”
(two variations)

circles
& lines

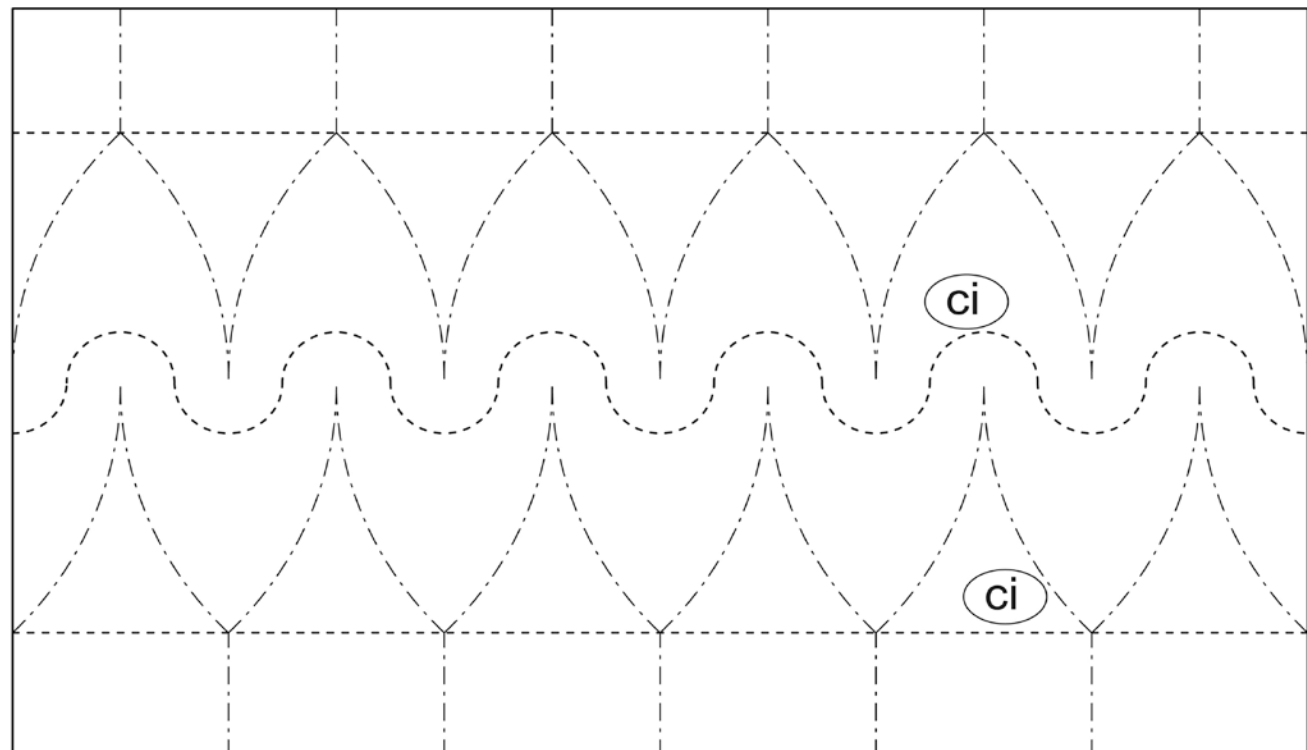
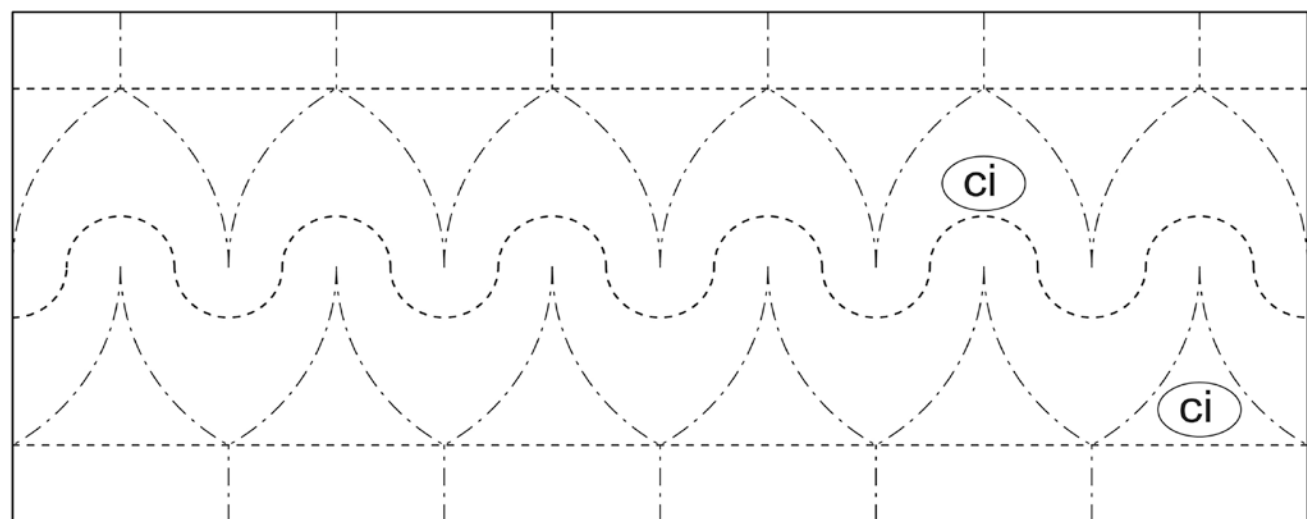



"Hexagonal column with cusps"

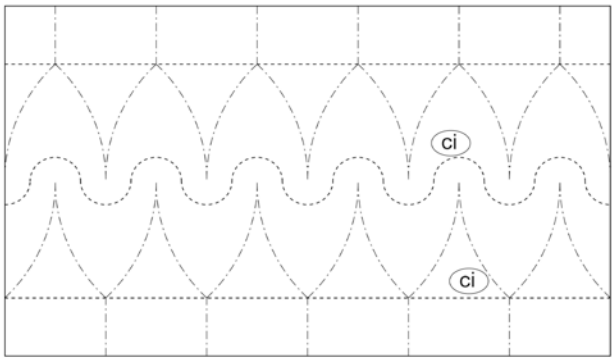
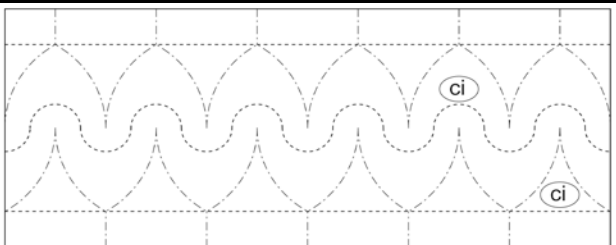

**circles
& lines**

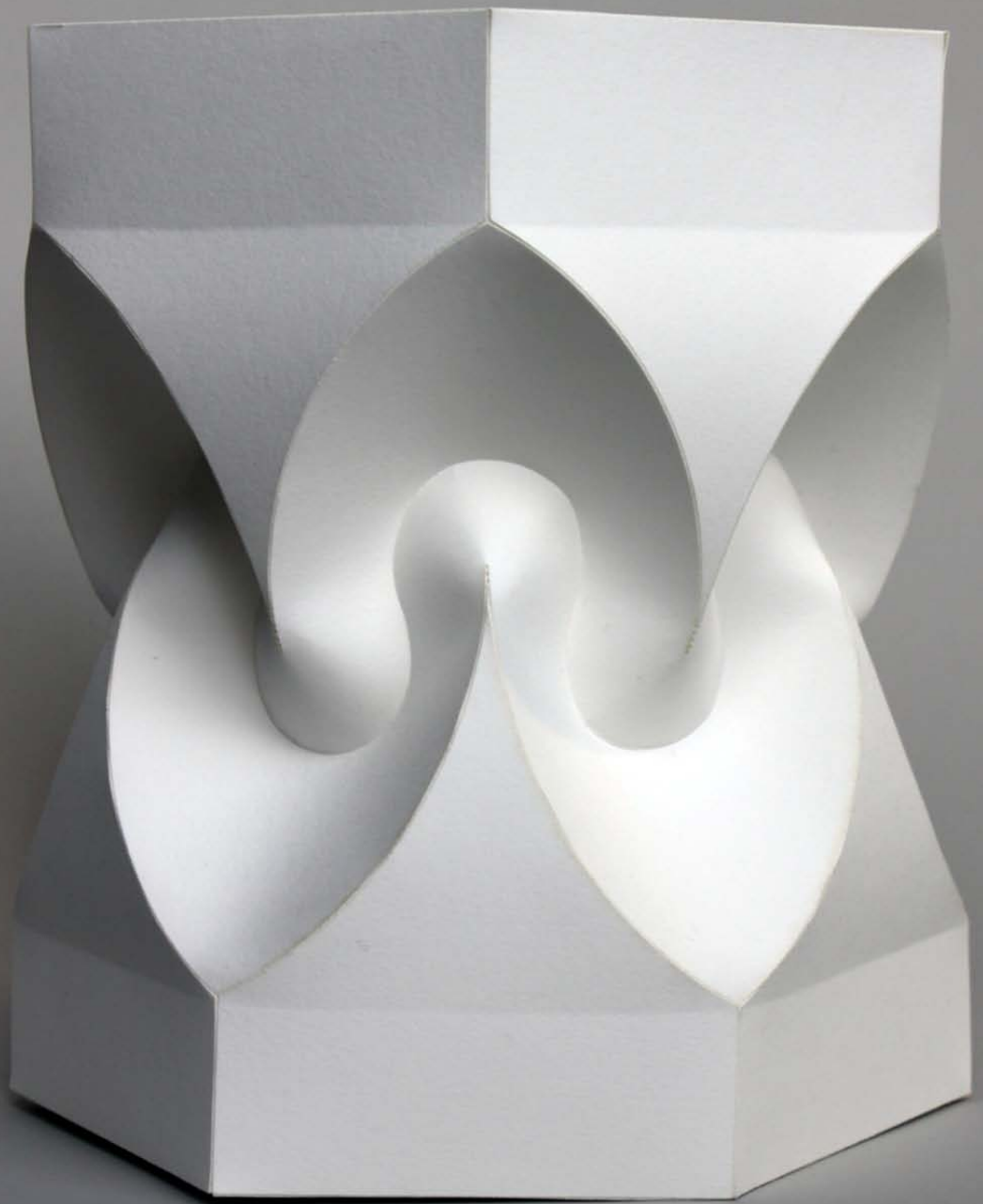

“4-lobed
cloverleaf”

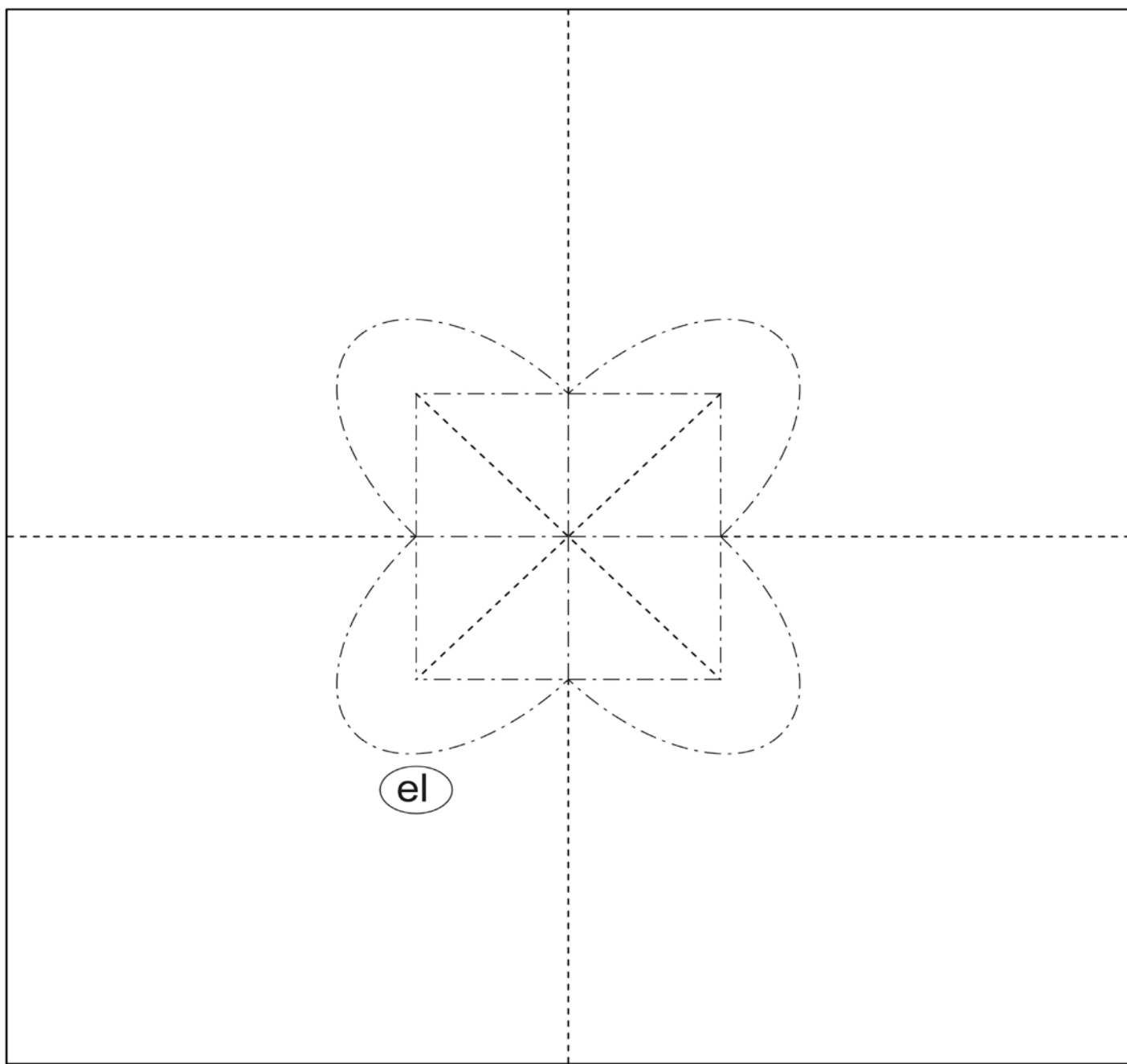

ellipses
& lines



"4-lobed
cloverleaf"

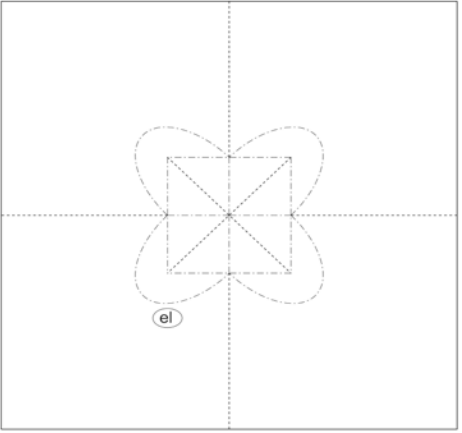

ellipses
& lines



design by David Huffman; recreated folding by Demaine, Demaine, Koschitz 2010



"One column"

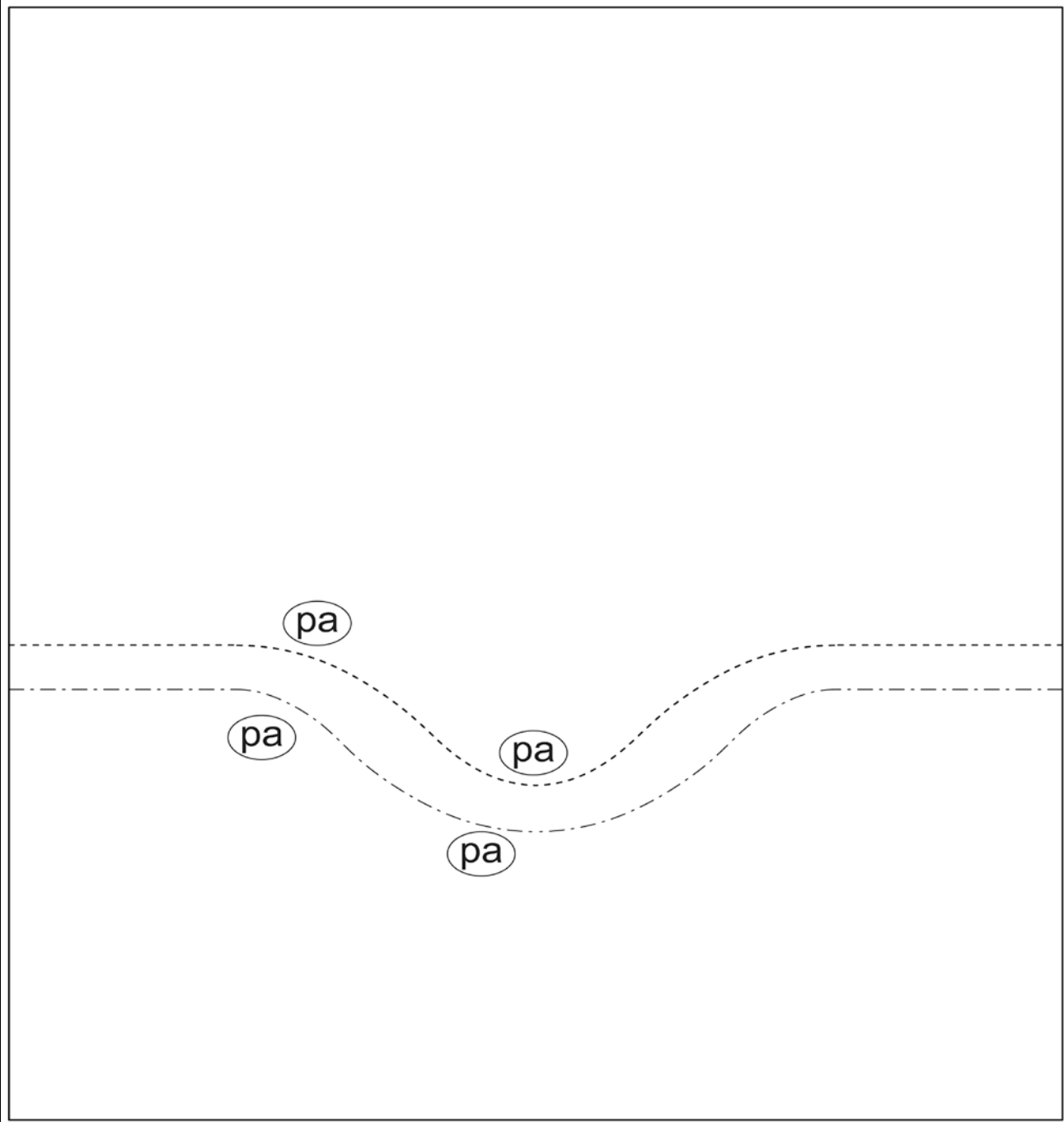

parabolas
& lines

design by David Huffman; recreated folding by Demaine, Demaine, Koschitz 2010



"One column"

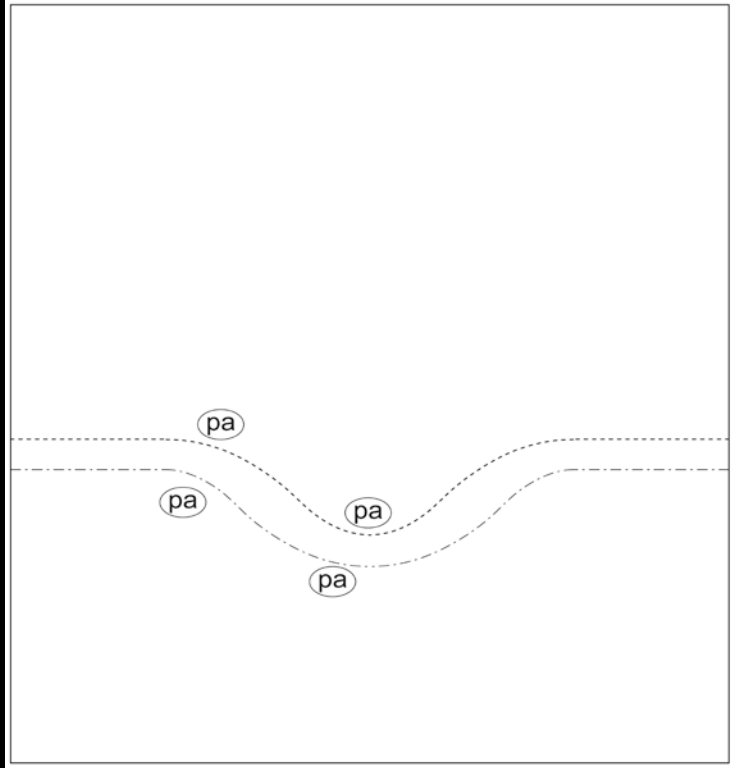

parabolas
& lines



design by David Huffman; recreated folding by Demaine, Demaine, Koschitz 2010

Huffman Family (May 2010)



Linda Marilyn Elise